

5-Megapixel C-Mount Code Reader V440-F

User-configurable barcode reader.

The **V440-F C-Mount Code Reader** with **WebLink 3.0** user interface is a highly configurable reader with a 36 frame-per-second 5 megapixel global shutter sensor. The V440-F can be deployed in virtually any application.

The C-mount lens, external lighting options, and 5 megapixel sensor optimize the V440-F for decoding:

- Very small codes (0.5 mil (0.12 mm) or smaller, depending on lens);
- Multiple codes in a single field of view (up to 400);
- Codes in large fields of view, at long distances, or at very high speeds.

The V440-F is pin-compatible with MicroHAWK V430-F readers, ensuring a clear upgrade path with all the same wiring accessories.

WebLink 3.0 – the intuitive, browser-based setup tool for the V440-F – allows you to configure highly complex applications quickly and easily.



Features

- Enhanced WebLink 3.0 functionality, including Matrix Mode and Configuration Database.
- 5 MP global shutter sensor.
- 36 FPS image acquisition.
- Higher FPS using pixel binning and region of interest (ROI) modes.
- C-mount lens-compatible.
- External lighting-compatible (dedicated strobe output).
- Smallest reader in its class.
- IP40-rated.
- Support for Digital I/O, RS-232, Ethernet TCP/IP, EtherNet/IP™, and PROFINET communications.
- PoE or direct 24V.

System Configuration

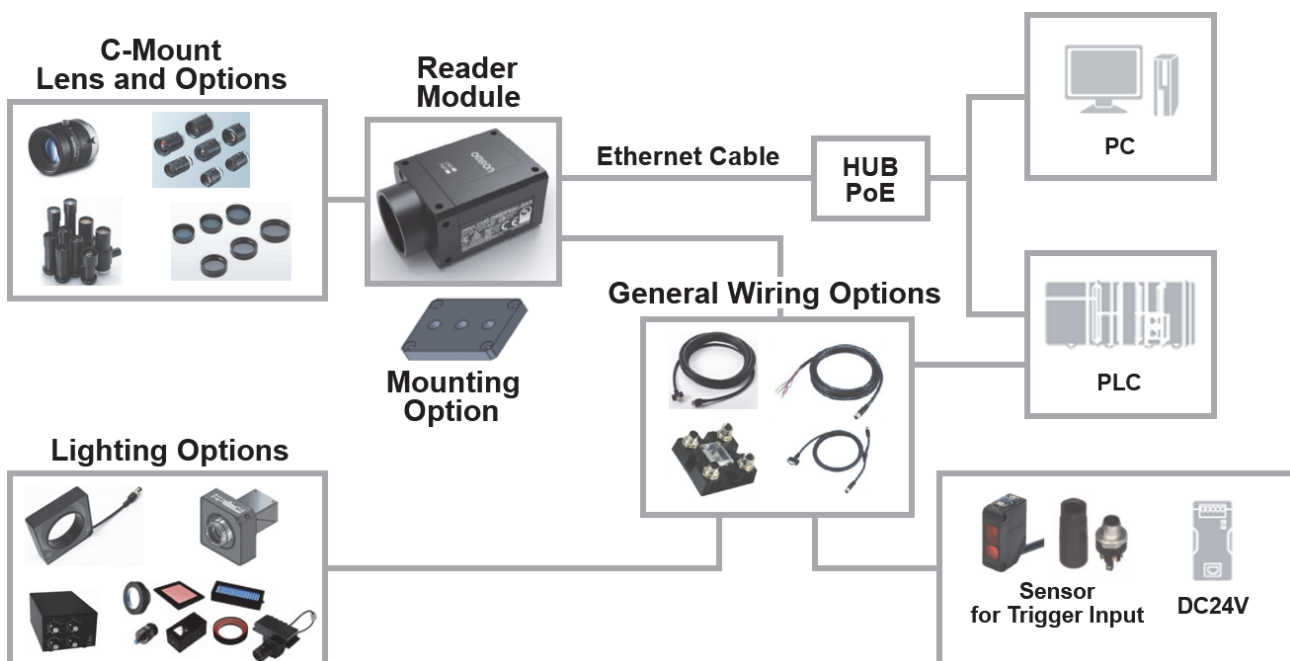

V440-F

Ordering Information

1. Reader Models

Appearance	Description	Part Number
	V440-F, No Optics, 5 MP, Mono, No Light, Plus Mode	V440-FXXX50M-NNP
	V440-F, No Optics, 5 MP, Mono, No Light, X-Mode	V440-FXXX50M-NNX

Note 1: V440-F readers are sold without lenses, lights, cables, or mounting. All of these items can be found in later sections of this datasheet.

Note 2: The V440-F uses all the same cables and interconnect accessories as the MicroHAWK V430-F, with the exception of the M12 Ethernet cables. The V440-F uses standard Ethernet cables. High-Flex TPE cables and Robot Ethernet cables are shown later in this datasheet.

2. Mounting Options

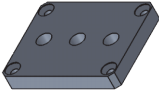
Appearance	Type	Part Number
	1/4-20 Reader Mounting Block Kit	V440-AM0

3. C-Mount Lens Options

The V440-F has a C-mount, and can be used with standard C-mount, telecentric, and macro lenses. Omron offers a variety of lenses at a variety of prices and resolutions for standard reading and code grading applications.

Three different C-mount lens sets are listed below for general reading and code grading. The tables include cross references to compatible polarizing filters and Smart Series Ring Lights.

When using the V440-F with Smart Series Ring Lights and a polarizer, the appropriate polarizing filter must be used on the lens.

Compact C-Mount Reading Lenses*

- Low Cost
- Small Size
- Reading Lens – 85 lp/mm
- Locking Screws for Focus and Iris
- F-Number of 1.2 to 16



Part Number	Focal Length	Minimum Working Distance	Size (MM) – Length x Diameter	Filter Size	Polarizer Part Number	Smart Ring Light Compatibility
98-9000167-01	6 MM	100	36.7 x 29.5	M27 P0.5	3Z4S-LE SV-PL270-SS	R-70/R-100
98-9000168-01	9 MM	100	35 x 29.5	M27 P0.5	3Z4S-LE SV-PL270-SS	R-70/R-100
98-9000169-01	12.5 MM	100	29.5 x 29.5	M25.5 P0.5	3Z4S-LE SV-PL255-SS	R-70/R-100
98-9000170-01	16 MM	100	29.5 x 29.5	M25.5 P0.5	3Z4S-LE SV-PL255-SS	R-70/R-100
98-9000171-01	25 MM	150	29.5 x 29.5	M25.5 P0.5	3Z4S-LE SV-PL255-SS	R-70/R-100
98-9000172-01	35 MM	250	29.5 x 29.5	M25.5 P0.5	3Z4S-LE SV-PL255-SS	R-70/R-100

*For working distances shorter than the minimum working distance specified for the lens, an extension ring is required to focus the lens.

Standard C-Mount Reading Lenses*

- Medium Size
- Reading Lens – 100 lp/mm
- Locking Screws for Focus and Iris
- F-Number of 1.4 to 16



Part Number	Focal Length	Minimum Working Distance	Size (MM) – Length x Diameter	Filter Size	Polarizer Part Number	Smart Ring Light Compatibility
3Z4S-LE SV-0614H	6 MM	100	57.5 x 42	M40.5 P0.5	3Z4S-LE SV-PL405-SS	R-100
3Z4S-LE SV-0814H	8 MM	100	52.5 x 39	M35.5 P0.5	3Z4S-LE SV-PL355-SS	R-100
3Z4S-LE SV-1214H	12 MM	100	51 x 30	M27 P0.5	3Z4S-LE SV-PL270-SS	R-70/R-100
3Z4S-LE SV-1614H	16 MM	100	47.5 x 30	M27 P0.5	3Z4S-LE SV-PL270-SS	R-70/R-100
3Z4S-LE SV-2514H	25 MM	150	36 x 30	M27 P0.5	3Z4S-LE SV-PL270-SS	R-70/R-100
3Z4S-LE SV-3514H	35 MM	200	45.5 x 44	M35.5 P0.5	3Z4S-LE SV-PL355-SS	R-100
3Z4S-LE SV-5014H	50 MM	300	57.5 x 44	M40.5 P0.5	3Z4S-LE SV-PL405-SS	R-100
3Z4S-LE SV-7525H	75 MM	1200	54.6 x 36	M34.0 P0.5	3Z4S-LE SV-PL340-SS	R-100
3Z4S-LE SV-10028H	100 MM	2000	71.6 x 39	M37.5 P0.5	3Z4S-LE SV-PL375-SS	R-100

*These are the standard lenses offered in the Omron Vision Accessories Catalog.

*For working distances shorter than the minimum working distance specified for the lens, an extension ring is required to focus the lens.

High-Resolution Code Reading / Grading C-Mount Lenses*

- Medium Size
- Reading / 1D and 2D Code Grading Lens – 145 lp/mm
- Locking Screws for Focus and Iris
- F-Number of 1.4 to 16



Part Number	Focal Length	Minimum Working Distance	Size (MM) – Length x Diameter	Filter Size	Polarizer Part Number	Smart Ring Light Compatibility
98-9000192-01	6 MM	100	51 x 39	M37.5 x 0.5	3Z4S-LE SV-PL375-SS	R-100
98-9000165-01	8 MM	100	51.5 x 29.5	M25.5 x 0.5	3Z4S-LE SV-PL255-SS	R-70/R-100
98-9000166-01	12 MM	100	51.5 x 29.5	M25.5 x 0.5	3Z4S-LE SV-PL255-SS	R-70/R-100
98-9000154-01	16 MM	100	46.0 x 29.5	M25.5 x 0.5	3Z4S-LE SV-PL255-SS	R-70/R-100
98-9000164-01	25 MM	100	46.5 x 29.5	M25.5 x 0.5	3Z4S-LE SV-PL255-SS	R-70/R-100
98-9000163-01	35 MM	200	41.5 x 29.5	M25.5 x 0.5	3Z4S-LE SV-PL255-SS	R-70/R-100

*For working distances shorter than the minimum working distance specified for the lens, an extension ring is required to focus the lens.

4. C-Mount Lens Polarizing Filters



Model	Filter Size
3Z4S-LE SV-PL225-SS	M22.5 P0.5
3Z4S-LE SV-PL255-SS	M25.5 P0.5
3Z4S-LE SV-PL270-SS	M27.0 P0.5
3Z4S-LE SV-PL305-SS	M30.5 P0.5
3Z4S-LE SV-PL340-SS	M34.0 P0.5
3Z4S-LE SV-PL355-SS	M35.5 P0.5
3Z4S-LE SV-PL375-SS	M37.5 P0.5
3Z4S-LE SV-PL405-SS	M40.5 P0.5
3Z4S-LE SV-PL520-SS	M52.0 P0.75
3Z4S-LE SV-PL550-SS	M55.0 P0.75
3Z4S-LE SV-PL620-SS	M62.0 P0.75

5. Non-Telecentric Macro C-Mount Lens Options for Small Codes

- Macro Lens – Low Cost, Small Size
- 0.5x Magnification – 17 × 14.2 mm Field of View
 - Able to Capture 2 mil (0.05 mm) Code at 7 PPE
- 1x Magnification – 8.5 × 7.1 mm Field of View
 - Able to Capture 1 mil (0.025 mm) Code at 7 PPE
- Use with External Lighting



Part Number	Description	Opt. Mag.	Working Distance (MM)	F#	Depth of Field (MM)	TV Distortion	V440-F FOV (MM)
3Z4S-LE VS-MC05-130	0.5x Macro Lens	0.5x	126.3	6.1	2.0	0.00%	17 × 14.2
3Z4S-LE VS-MC1-80	1x Macro Lens	1x	82.4	8.14	0.7	0.00%	8.5 × 7.1

6. Telecentric C-Mount Lens and Lighting Options for Small Codes

- High-Resolution Telecentric Lens – 150 lp/mm
- 1x Magnification – 8.5 × 7.1 mm Field of View
 - Able to capture 1 mil (0.024 mm) Code Size at 7 PPE
- 2x Magnification – 4.25 × 3.55 mm Field of View
 - Able to capture 0.5 mil (0.012 mm) Code Size at 7 PPE
- 65 or 110 mm Working Distance
- Coaxial Lighting Option or use with External Lighting



Part Number	Description	Opt. Mag.	Working Distance (MM)	F#	NA	Depth of Field (MM)	TV Distortion	V440-F FOV (MM)
3Z4S-LE VS-TCH1-65-O	1x Telecentric Lens	1x	68.8	9.9	0.05	0.6	0.01%	8.5 × 7.1
3Z4S-LE VS-TCH1-110-O	1x Telecentric Lens	1x	110.3	10.5	0.048	0.6	0.02%	8.5 × 7.1
3Z4S-LE VS-TCH2-65-O	2x Telecentric Lens	2x	65	13.6	0.074	0.3	0.01%	4.25 × 3.55
3Z4S-LE VS-TCH2-110-O	2x Telecentric Lens	2x	110.3	13.6	0.074	0.3	0.02%	4.25 × 3.55
3Z4S-LE VS-TCH1-65CO-O	1x Telecentric Lens with Coaxial Light	1x	68.8	9.9	0.05	0.6	0.03%	8.5 × 7.1
3Z4S-LE VS-TCH1-110CO-O	1x Telecentric Lens with Coaxial Light	1x	110.8	10.5	0.048	0.6	0.03%	8.5 × 7.1
3Z4S-LE VS-TCH2-65CO-O	2x Telecentric Lens with Coaxial Light	2x	65	13.5	0.074	0.3	0.03%	4.25 × 3.55
3Z4S-LE VS-TCH2-110CO-O	2x Telecentric Lens with Coaxial Light	2x	110.8	13.5	0.074	0.3	0.03%	4.25 × 3.55

Telecentric Lens Coaxial Lighting – Option 1

- Red, White, or Blue Spot Light for Coaxial Lens (8 mm dia.)
- Analog Lighting Controller
- Extension Cable

Part Number	Description*
FLV-EP0803R	Spot Light, Red (Fits TCH Telecentric Lens)
FLV-EP0803W	Spot Light, White (Fits TCH Telecentric Lens)
FLV-EP0803B	Spot Light, Blue (Fits TCH Telecentric Lens)
FLV-ATC10405	Analog Lighting Controller for FLV-EP Series
FLV-XC1EP	Extension Cable (between Light and Controller) 1 Meter
FLV-XC2EP	Extension Cable (between Light and Controller) 2 Meters
FLV-XC3EP	Extension Cable (between Light and Controller) 3 Meters
FLV-XC5EP	Extension Cable (between Light and Controller) 5 Meters

*Note: See the **Omron Vision Accessories Catalog** for full descriptions.

Important: This option uses standard components available in Japan. Please note that this power supply cannot be sold in the U.S. or the EU. Refer to **Telecentric Lens Coaxial Lighting – Option 2** for alternate components.

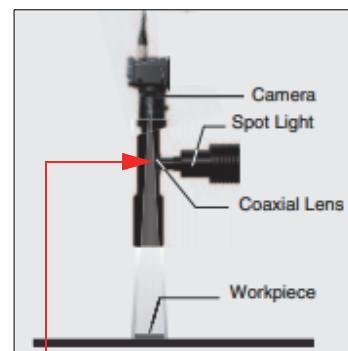

Telecentric Lens Coaxial Lighting – Option 2

- Blue Spot Light for Coaxial Lens (8 mm dia.)
- 24V DC / 0.7W
- Flying Leads Extension Cable to Power Source
- Optional Power Supply

Part Number	Description
98-9000304-01	Kit, Spotlight, Blue, Telecentric Lens with Flying Leads Extension Cable
NER-011504100	24VDC 2.5A DIN Mount Power Supply*
NER-030028300	AC Power Cord for DSPxx Power Supply, U.S.*
NER-030028400	AC Power Cord for DSPxx Power Supply, EU*

*Important: This option can be sold in the U.S., EU, and all other regions, as it can be powered directly from 24V, or can use the listed UL-compliant and CE-compliant **DSP60** power supply.

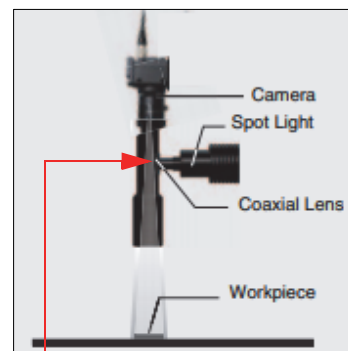

7. Cables

General Wiring Options

Appearance	Category	Length / Spec	Part Number	
	Standard Ethernet Cables - Industrial High-Flex GigE Ethernet Cables with Jack Screws and RJ45 Connector*	2 Meters	98-000133-01	
		5 Meters	98-000134-01	
		7 Meters	98-000134-02	
 	Reader to QX-1 Interconnect Cables M12 Socket to M12 Plug QX-1 is used as breakout module for common IO signals and power.	1 Meter	V430-WQ-1M	
	M12 Socket to M12 Plug, with Power Filter	300 mm	V430-WQF-1M	
	Reader to QX-1 Interconnect Cables M12 Socket to M12 Plug QX-1 is used as breakout module for common IO signals and power.	3 Meters	V430-WQ-3M	
	M12 Socket to M12 Plug QX-1 is used as breakout module for common IO signals and power.	5 Meters	V430-WQ-5M	
	QX-1 M12 to Smart Light Power and Strobe Control Cables M12 Plug on QX-1 to 5 Pin Socket on Light	3 Meters – Continuous Power	61-000204-01	
		3 Meters – Strobe Control	61-000218-01	
	Y Cable, Reader/Power and Smart Light Power (Continuous On)	1 Meter	61-9000135-01	
	Y Cable, Reader/Power and Smart Light Strobe Control	1 Meter	61-9000137-01	
 	M12 to Flying Leads Cable, Straight Power, IO, RS-232, USB M12 to Flying Leads Cable, with Power Filter	3 Meters	V430-W8-3M V430-W8F-3M	
	M12 to Flying Leads Cable, Straight Power, IO, RS-232, USB M12 to Flying Leads Cable, with Power Filter	5 Meters	V430-W8-5M V430-W8F-5M	
		M12 to RS-232 Breakout	1 Meter	V430-WR-1M
			3 Meters	V430-WR-3M
	Reader to QX-1 Interconnect Cables with RS-232 Breakout	2.7 Meters	V430-WQR-3M	
	Reader to QX-1 Interconnect Cables with USB Keyboard Wedge Breakout	2.7 Meters	V430-WQK-3M	

***Important:** Standard Omron FJ-VSG Ethernet cables are available in alternative and longer lengths.



8. Lighting Options

The V440-F is designed for use with external lighting. It can be equipped with any vendor's continuous power or strobe lighting. Strobe lights are triggered using Output 3 on the M12 IO connector through a flying leads cable.

Omron also offers a line of Smart Lights that can be used in continuous or strobed mode. NERLITE Smart Series Lights have a built-in strobe controller, so no external strobe controller is needed. Dedicated cable sets allow you to wire the NERLITE Smart Series Lights directly to the V440-F.

NERLITE Smart Series Lights include Ring Lights, DOALs, Large Area Bar Lights (MAX Lights), and a dedicated label-reading light called Pharmalite. Ring Lights are the most appropriate choice for the V440-F. Ring Lights, Ring Light accessories, and mounting brackets are show below.

NERLITE Smart Series R-70 and R-100 Ring Lights

Product	Appearance	Type	Part Number
V440-F Smart Series Ring Light Kits 		R-70, 70 mm RED Ring Light	NER-011660900G*
		R-70, 70 mm WHITE Ring Light	NER-011660910G
		R-70, 70 mm BLUE Ring Light	NER-011660920G
		R-100, 100 mm RED Ring Light	NER-011661100G*
		R-100, 100 mm WHITE Ring Light	NER-011661110G
		R-100, 100 mm BLUE Ring Light	NER-011661120G

***Note:** The R-70 and R-100 Red Ring Lights are normally stock lights with short lead times. Blue and White Ring Lights are subject to standard NERLITE lead times. Check on availability before placing order.

NERLITE Smart Series R-70 and R-100 Ring Light Polarizer Kits

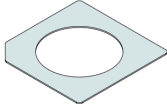
Appearance	Type	Part Number
	R-70 Smart Series Ring Light Polarizer Kit	98-9000301-01*
	R-100 Smart Series Ring Light Polarizer Kit	98-9000302-01*

***Note:** Smart Series Ring Light Polarizer Kits must be used in conjunction with a cross-polarizer on the lens. See lens polarizer section of the datasheet to determine the correct part number to match the filter thread size of the lens.

NERLITE Smart Series R-70 and R-100 Ring Light Mounting Kits

Appearance	Type	Part Number
	R-70 Smart Series Ring Light Mounting Kit	V440-AM1*
	R-100 Smart Series Ring Light Mounting Kit	V440-AM2*

***Note:** The C-Mount lens nests down inside the light aperture. The R-70 has a 43.4 mm opening. The R-100 has a 69.5 mm opening. Larger diameter lenses may not fit inside the R-70 ring light. Please see light size compatibility chart in the lens tables.

NERLITE Smart Series R-70 and R-100 Ring Light Specifications, Dimensions, Connections

Size	Part Number	Description	Wavelength	Current @ 24 V	Strobe Current	Millicandela Continuous	Millicandela Strobe
R-70	NER-011660900G	70 mm, RED	623 nm	172 mA	1.2 A	349281	3062913
	NER-011660910G	70 mm, WHITE	6700 K	160 mA	850 mA	352205	1739631
	NER-011660920G	70 mm, BLUE	470 nm	160 mA	850 mA	143217	618814
R-100	NER-011661100G	100 mm, RED	623 nm	255 mA	1.7 A	516015	4370388
	NER-011661110G	100 mm, WHITE	6700 K	235 mA	1.1 A	495814	2338577
	NER-011661120G	100 mm, BLUE	470 nm	235 mA	1.1 A	201005	848215

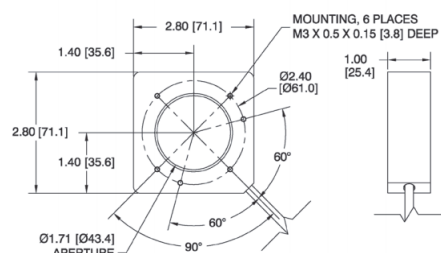

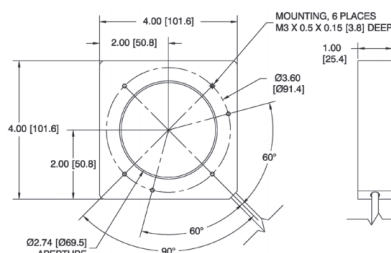

Smart Series R-70 Ring Light Dimensions



Smart Series R-100 Ring Light Dimensions

9. Other Accessories

Appearance	Category	Length / Spec	Part Number
	QX-1 Interconnect Module – Power, Trigger, Smart Light Control Breakout	N/A	98-000103-02
	QX-1 Photo Sensor, M12 4-Pin Plug, NPN	2 Meters – Light ON/ Dark ON	99-9000016-01
	QX-1 Field-Wireable M12 4-Pin Plug for Any Trigger Source or Photo Sensor	Screw Terminals	98-9000239-01

System Configuration Examples

System Configuration Example 1: FLV Series or Other External Lighting

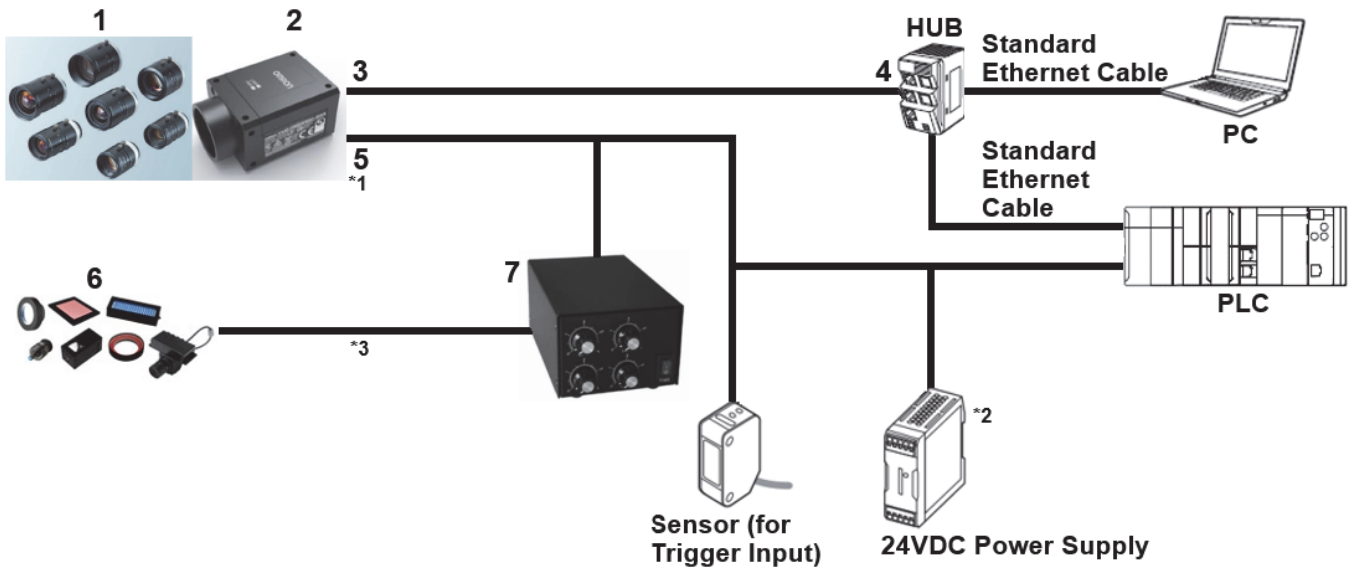

Drawing Reference	Category	Part Number
1	C-Mount Lens	3Z4S-□□, 98-9000□□□-01
2	V440-F C-Mount 5 MP Camera	V440-FXXXY50M-NN□
3	Industrial High-Flex GigE Ethernet Cable with Jack Screws and RJ45 Connector	98-00013□-0□
4	PoE (Power over Ethernet)	Select a cable that can supply power via Ethernet.
	Industrial Switching HUB	Example: W4S1 Series
5	M12-to-Flying Leads Cable	V430-W8□□□-□M
6	FLV Lighting	FLV-□
7	Lighting Controller	FLV-ATC□, 3Z4S-LTIDGB□

*1. The V430-WQ cable (excluding V430-WQR / V430-WQK) can be used as an extension of the V430-W8 cable.

*2. A 24VDC power supply is not needed for the V440-F if a PoE switching HUB is used.

*3. Any vendor's lighting and power supply can be used with the V440-F. The I/O cable provides strobe signal to light power supply.

System Configuration Example 2: NERLITE Smart Series Light with QX-1

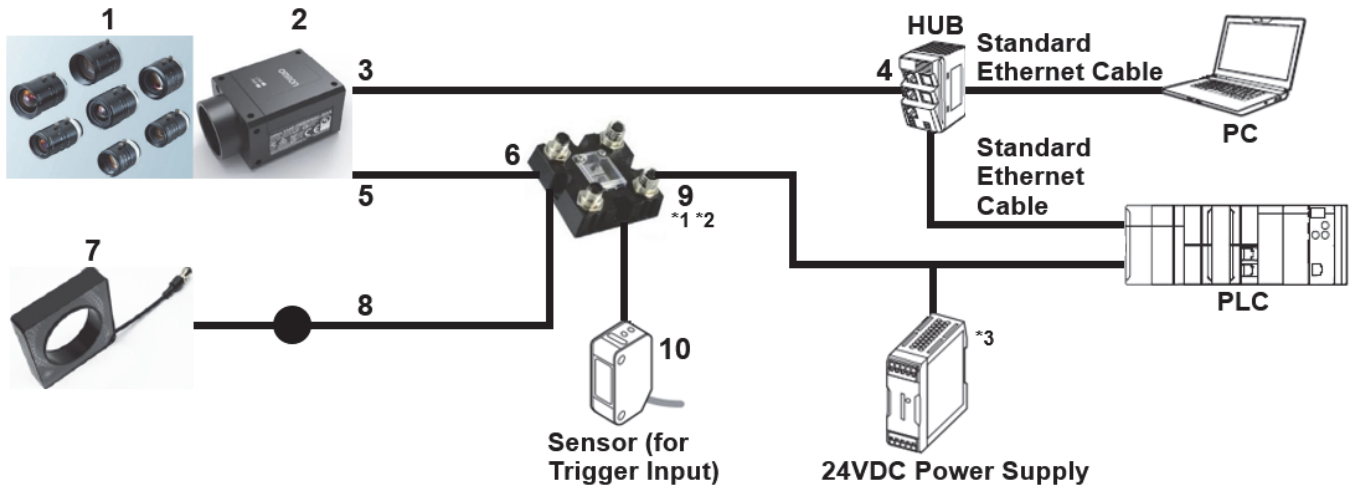

Drawing Reference	Category	Part Number
1	C-Mount Lens	3Z4S-□□, 98-9000□□□-01
2	V440-F C-Mount 5 MP Camera	V440-FXXXY50M-NN□
3	Industrial High-Flex GigE Ethernet Cable with Jack Screws and RJ45 Connector	98-00013□-0□
4	PoE (Power over Ethernet)	Select a cable that can supply power via Ethernet.
	Industrial Switching HUB	Example: W4S1 Series
5	Reader-to-QX-1 Interconnect Cable	V430-WQ-1M
6	QX-1 Interface Device	98-000103-02
7	NERLITE Smart Series R-70 or R-100 Ring Light	NER-01166□□□□G
8	Integrated Light Cable	61-0002□□-01
9	M12-to-Flying Leads Cable	V430-W8□□□-□M
10	QX-1 Photo Sensor	98-9000016-01
	QX-1 Field-Wireable M12 4-Pin Plug for Any Trigger Source or Photo Sensor	98-9000239-01

*1. The V430-WQ cable (excluding V430-WQR / V430-WQK) can be used as an extension of the V430-W8 cable.

*2. It is possible to connect a 97-000012-01 power supply instead of V430-W8. However, since there is no I/O line, you cannot connect to the sensor or PLC.

*3. A 24VDC power supply is not needed for the V440-F if a PoE switching HUB is used.

System Configuration Example 3: NERLITE Smart Series Light without QX-1

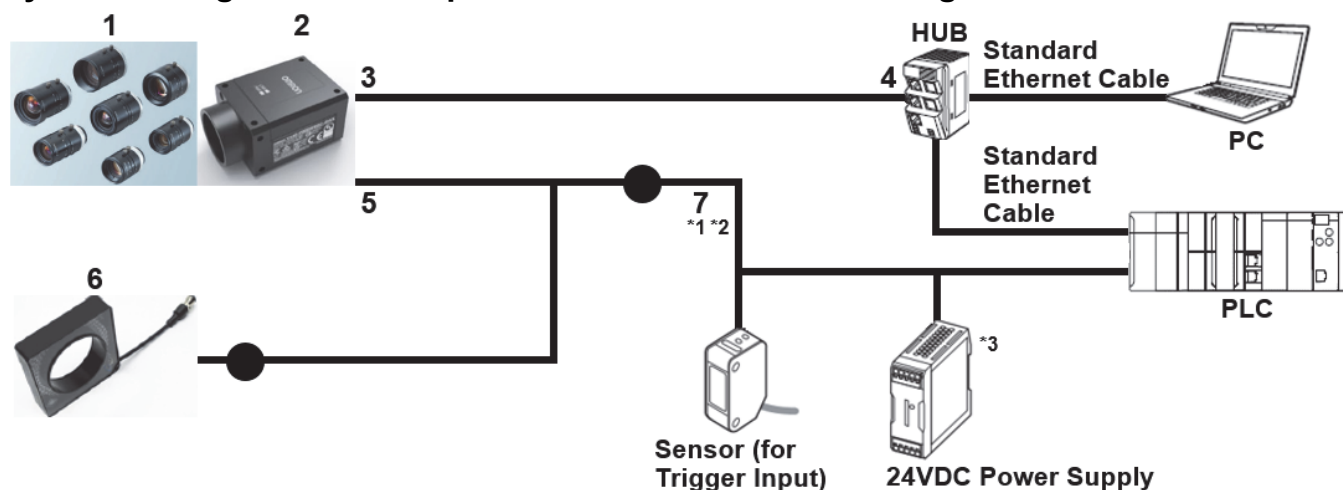

Drawing Reference	Category	Part Number
1	C-Mount Lens	3Z4S-□□, 98-9000□□□-01
2	V440-F C-Mount 5 MP Camera	V440-FXXXY50M-NN□
3	Industrial High-Flex GigE Ethernet Cable with Jack Screws and RJ45 Connector	98-00013□-0□
4	PoE (Power over Ethernet)	Select a cable that can supply power via Ethernet.
	Industrial Switching HUB	Example: W4S1 Series
5	Integrated Light Y Cable	61-900013□-01
6	NERLITE Smart Series R-70 or R-100 Ring Light	NER-01166□□□□G
7	M12-to-Flying Leads Cable	V430-W8□□□-□M

*1. The V430-WQ cable (excluding V430-WQR / V430-WQK) can be used as an extension of the V430-W8 cable.

*2. It is possible to connect a 97-000012-01 power supply instead of V430-W8. However, since there is no I/O line, you cannot connect to the sensor or PLC.

*3. A 24VDC power supply is not needed for V440-F if a PoE switching HUB is used.

System Configuration Example 4: Minimum Power over Ethernet (PoE) Configuration

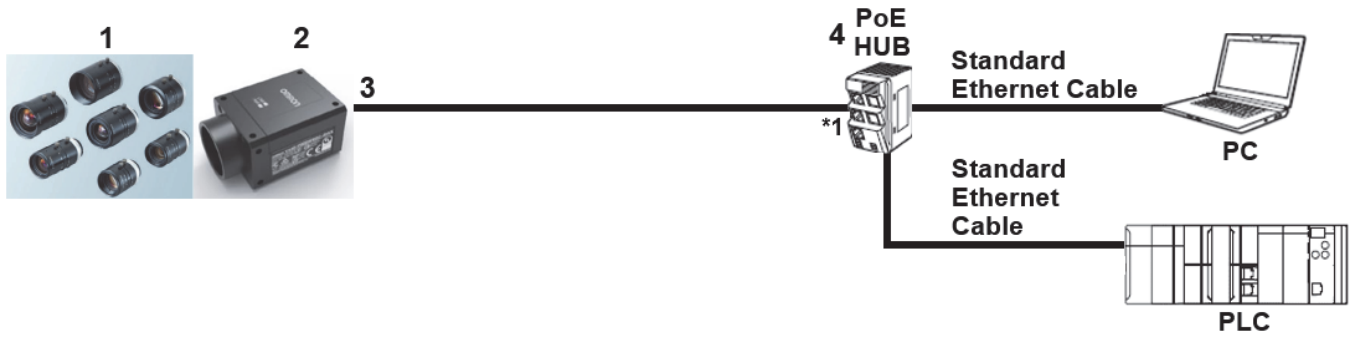

Drawing Reference	Category	Part Number
1	C-Mount Lens	3Z4S-□□, 98-9000□□□-01
2	V440-F C-Mount 5 MP Camera	V440-FXXXY50M-NN□
3	Industrial High-Flex GigE Ethernet Cable with Jack Screws and RJ45 Connector	98-00013□-0□
4	PoE (Power over Ethernet) HUB	Select a cable that can supply power via Ethernet.

*1. A 24VDC power supply is not needed for the V440-F if a PoE switching HUB is used.

System Configuration Example 5: Minimum External Power Configuration

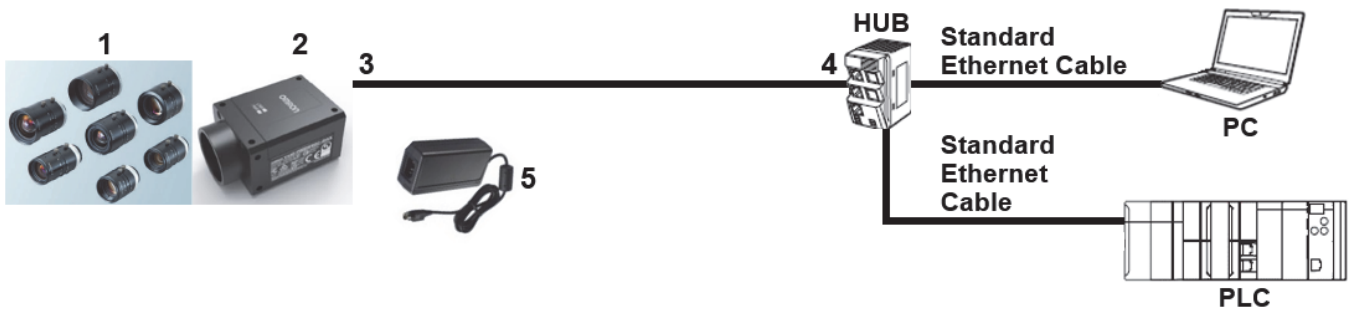

Drawing Reference	Category	Part Number
1	C-Mount Lens	3Z4S-□□, 98-9000□□□-01
2	V440-F C-Mount 5 MP Camera	V440-FXXXY50M-NN□
3	Industrial High-Flex GigE Ethernet Cable with Jack Screws and RJ45 Connector	98-00013□-0□
4	Industrial Switching HUB	Example: W4S1 Series
5	Power Supply, 100-240VAC, +24VDC, M12 12-Pin Socket	97-000012-01

System Configuration Example 6: USB Configuration

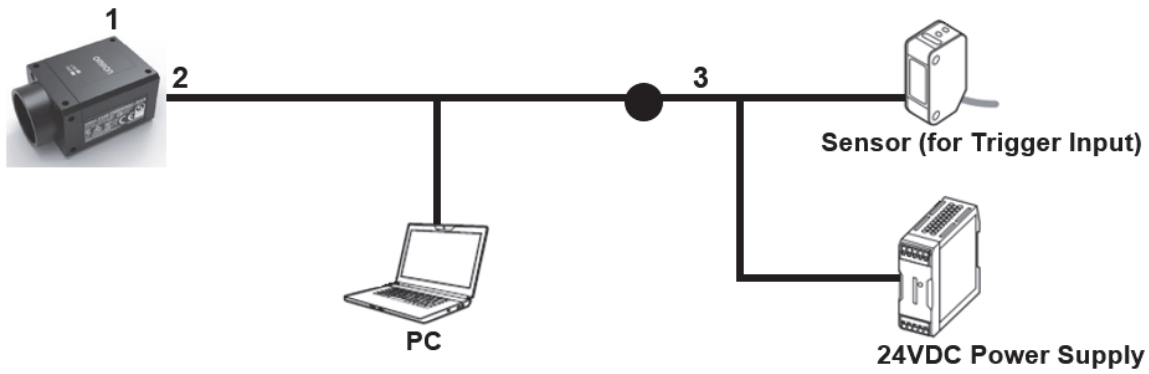

Drawing Reference	Category	Part Number
1	V440-F C-Mount 5 MP Camera	V440-FXXX50M-NN□
2	Reader-to-QX-1 Interconnect Cable with USB Keyboard Wedge Breakout	V430-WQK-3M*
3	M12-to-Flying Leads Cable	V430-W8□□□□-□M

*Insert the V430-WQK-3M cable between the V440-F and the V430-W8□□□□-□M cable.

System Configuration Example 7: RS-232C Configuration

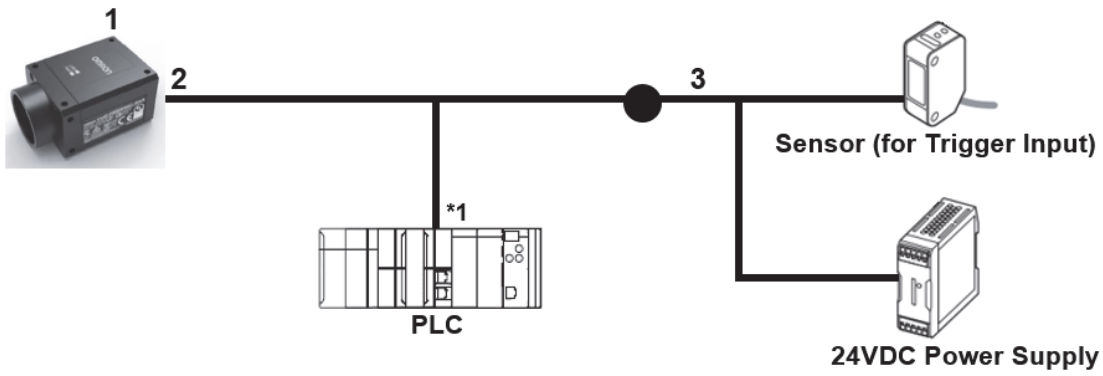

Drawing Reference	Category	Part Number
1	V440-F C-Mount 5 MP Camera	V440-FXXXY50M-NN□
2	Reader-to-QX-1 Interconnect Cable with RS-232 Breakout	V430-WQR-3M*
3	M12-to-Flying Leads Cable	V430-W8□□□-□M

*Insert the V430-WQR-3M cable between the V440-F and the V430-W8 cable.

*1. If connecting Omron's CS/CJ/NJ Controller, check the connector shape and signal lines (pin assignments) and prepare the additional RS-232C conversion cable. If connecting to Omron's NX Machine Automation Controller, no additional RS-232C cable is required.

10. Determining the Optical Setup

The following four-step process determines the optimal lens focal length, field of view, and camera standoff to read the intended code successfully.

Step 1: Determine the minimum element size of the code (usually expressed in mils).

For a 1D barcode, this is the size of the thinnest bar of the code. For a 2D code, this is the size of a single square element in the code. The element size is usually known by the customer.



Step 2: Use the guidelines below to determine the approximate PPE (Pixels Per Element) required to read the code successfully.

Pixels Per Element (PPE) is defined as the number of pixels that span the smallest feature of the code. A certain minimum number of pixels is required to read successfully. For 1D codes, PPE refers to the number of image pixels across the narrowest bar in the barcode. For 2D codes, PPE refers to the number of image pixels across a single cell within the 2D code.

The following are general guidelines for typical PPE requirements based on the code type and application. It is acceptable to have too many Pixels Per Element. It can however slow down the read time.

Code Type	Minimum PPE	Preferred PPE	PPE for Code Grading
1D Code – High Contrast Label	1.6	2	5
1D Code – Direct Part Mark	2	2.5	5
2D Code – High Contrast Label	2.75	3.5 to 5	8 to 10
2D Code – Direct Part Mark	3.5	5	8 to 10

Step 3: Based on the suggested PPE from the above table, use the table below to determine the ideal field of view that delivers the required PPE.

The **Readability Table** below shows, for all common code sizes, the maximum field of view that will result in the required PPE. Results for **2, 3.5, 5, and 10** PPE are given.

FOV Size (mm) to Achieve a Specific PPE for all Common Code Sizes				
Thin Bar or 2D Cell Size	PPE = 2	PPE = 3.5	PPE = 5	PPE = 10
0.5 mil (0.0127 mm)	15.6	8.9	6.3	3.1
1 mil (0.0254 mm)	31.3	17.9	12.5	6.3
1.5 mil (0.0381 mm)	46.9	26.8	18.8	9.4
2 mil (0.0508 mm)	62.6	35.8	25.0	12.5
2.5 mil (0.0635 mm)	78.2	44.7	31.3	15.6
3.3 mil (0.084 mm)	103.5	59.1	41.4	20.7
5 mil (0.127 mm)	156.5	89.4	62.6	31.3
7.5 mil (0.19 mm)	234.1	133.8	93.6	46.8
10 mil (0.25 mm)	312.9	178.8	125.2	62.6
13 mil (0.33 mm)	406.6	232.3	162.6	81.3
15 mil (0.38 mm)	469.4	268.2	187.8	93.9
20 mil (0.5 mm)	625.9	357.6	250.3	125.2
30 mil (0.76 mm)	936.3	535.0	374.5	187.3
40 mil (1 mm)	1251.7	715.3	500.7	250.3
50 mil (1.25 mm)	1564.6	894.1	625.9	312.9

Step 4: Based on ideal field of view, use the Field of View / Working Distance charts below to choose the best lens and camera standoff distance combination that most closely matches the application requirements.

Example: Read a 2D, 7.5 mil code.

From the guidelines we can determine that **3.5 PPE** is a good starting point.

From the **PPE to FOV table** above, we see the ideal field of view for achieving a **PPE of 3.5** on a **7.5 mil code** is **133.8 mm**.

From the table below, we see there are multiple lens options and working distance options that come close*.

- **Option 1:** F = 9 mm, Working Distance = 150.
- **Option 2:** F = 12.5 mm, Working Distance = 200.
- **Option 3:** F = 16 mm, Working Distance = 250.

***Note:** Please note that it normal to interpolate between the set working distances in the chart to come up with the best answer. ALWAYS TEST the solution on your exact samples. You can always move the camera in to increase the resolution.

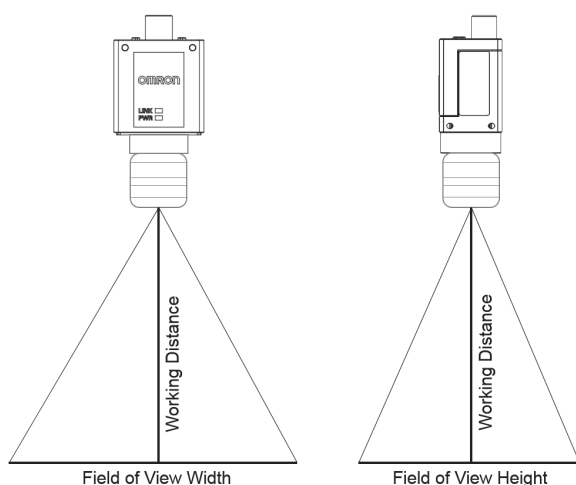

General lens formulas for any combination, given working distance, focal length, or field of view width:

Field of View Width = 8.5 x Working Distance / Focal Length

Field of View Height = 7.093 x Working Distance / Focal Length

Focal Length = 8.5 x Working Distance / Field of View Width

Working Distance = Field of View Width x Focal Length / 8.5

Field of View for 25* to 500 mm Working Distance

Field of View (mm x mm) at Specific Working Distances (mm)												
Lens FL	25	50	75	100	150	200	250	300	350	400	450	500
F = 6	35 x 30	71 x 59	106 x 89	142 x 118	213 x 177	283 x 236	354 x 296	425 x 355	496 x 414	567 x 473	638 x 532	708 x 591
F = 8	27 x 22	53 x 44	80 x 66	106 x 89	159 x 133	213 x 177	266 x 222	319 x 266	372 x 310	425 x 355	478 x 399	531 x 443
F = 9	24 x 20	47 x 39	71 x 59	94 x 79	142 x 118	189 x 158	236 x 197	283 x 236	331 x 276	378 x 315	425 x 355	472 x 394
F = 12.5	17 x 14	34 x 28	51 x 43	68 x 57	102 x 85	136 x 113	170 x 142	204 x 170	238 x 199	272 x 227	306 x 255	340 x 284
F = 16	13 x 11	27 x 22	40 x 33	53 x 44	80 x 66	106 x 89	133 x 111	159 x 133	186 x 155	213 x 177	239 x 199	266 x 222
F = 25	9 x 7	17 x 14	26 x 21	34 x 28	51 x 43	68 x 57	85 x 71	102 x 85	119 x 99	136 x 113	153 x 128	170 x 142
F = 35	6 x 5	12 x 10	18 x 15	24 x 20	36 x 30	49 x 41	61 x 51	73 x 61	85 x 71	97 x 81	109 x 91	121 x 101
F = 50	4 x 4	9 x 7	13 x 11	17 x 14	26 x 21	34 x 28	43 x 35	51 x 43	60 x 50	68 x 57	77 x 64	85 x 71
F = 75	3 x 2	6 x 5	9 x 7	11 x 9	17 x 14	23 x 19	28 x 24	34 x 28	40 x 33	45 x 38	51 x 43	57 x 47
F = 100	2 x 2	4 x 4	6 x 5	9 x 7	13 x 11	17 x 14	21 x 18	26 x 21	30 x 25	34 x 28	38 x 32	43 x 35

*For working distances shorter than the minimum working distance specified for the lens, an extension ring is required to focus the lens.

Field of View at 600 to 2500 mm Working Distance

Field of View (mm x mm) at Specific Working Distances (mm)											
Lens FL	600	700	800	900	1000	1250	1500	1750	2000	2500	
F = 6	850 x 709	992 x 828	1133 x 946	1275 x 1064	1417 x 1182	1771 x 1478	2125 x 1773	2479 x 2069	2833 x 2364	3542 x 2956	
F = 8	638 x 532	744 x 621	850 x 709	956 x 798	1063 x 887	1328 x 1108	1594 x 1330	1859 x 1552	2125 x 1773	2656 x 2217	
F = 9	567 x 473	661 x 552	756 x 631	850 x 709	944 x 788	1181 x 985	1417 x 1182	1653 x 1379	1889 x 1576	2361 x 1970	
F = 12.5	408 x 340	476 x 397	544 x 454	612 x 511	680 x 567	850 x 709	1020 x 851	1190 x 993	1360 x 1135	1700 x 1419	
F = 16	319 x 266	372 x 310	425 x 355	478 x 399	531 x 443	664 x 554	797 x 665	930 x 776	1063 x 887	1328 x 1108	
F = 25	204 x 170	238 x 199	272 x 227	306 x 255	340 x 284	425 x 355	510 x 426	595 x 497	680 x 567	850 x 709	
F = 35	146 x 122	170 x 142	194 x 162	219 x 182	243 x 203	304 x 253	364 x 304	425 x 355	486 x 405	607 x 507	
F = 50	102 x 85	119 x 99	136 x 113	153 x 128	170 x 142	213 x 177	255 x 213	298 x 248	340 x 284	425 x 355	
F = 75	68 x 57	79 x 66	91 x 76	102 x 85	113 x 95	142 x 118	170 x 142	198 x 166	227 x 189	283 x 236	
F = 100	51 x 43	60 x 50	68 x 57	77 x 64	85 x 71	106 x 89	128 x 106	149 x 124	170 x 142	213 x 177	

Important: See [V440-F Lens Selection Based on Focal Length](#) on the next page.

V440-F

V440-F Lens Selection Based on Focal Length

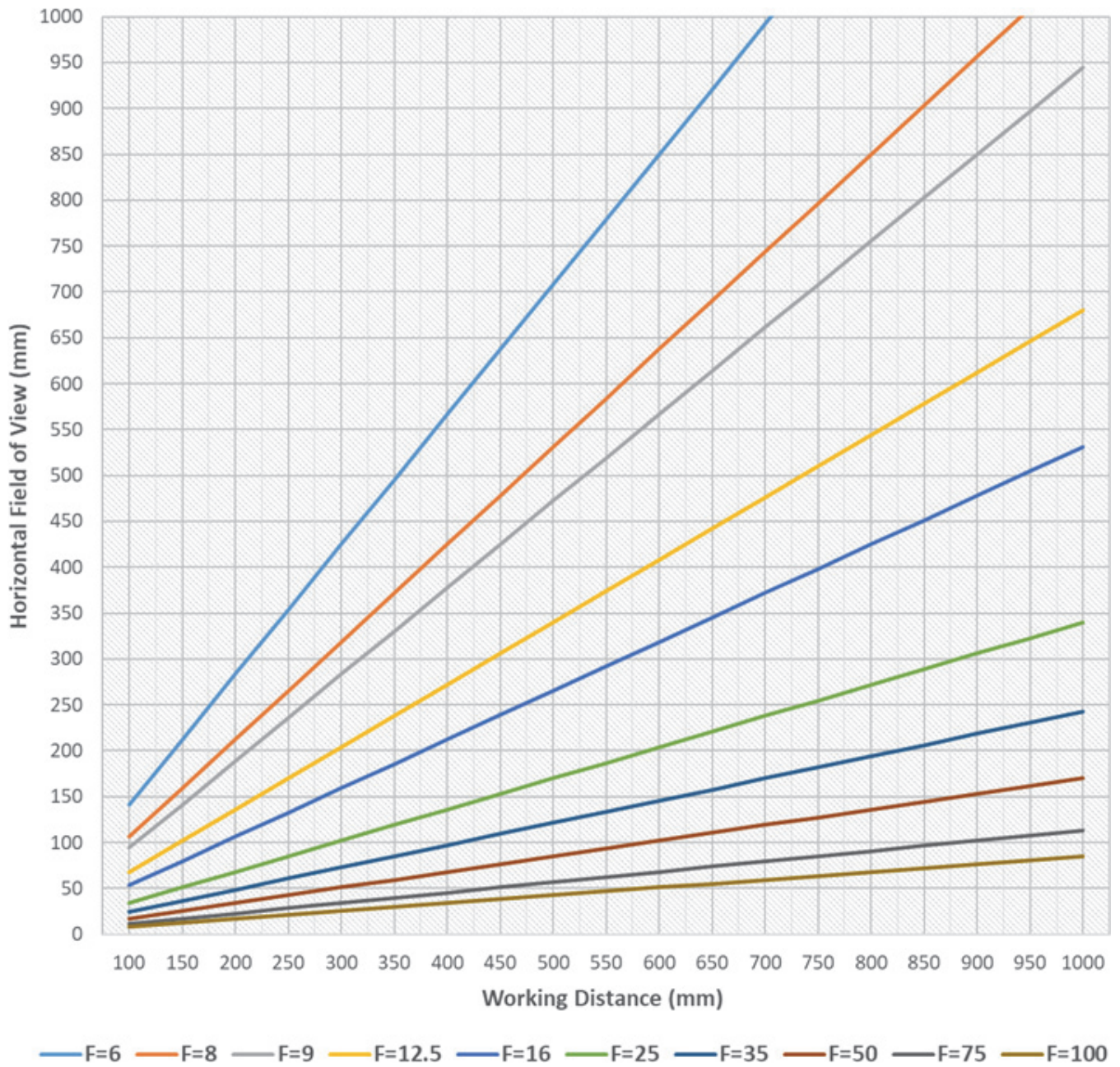

Ratings and Specifications

V440-F		
Symbologies *1	1D Symbologies	Code 39, Code 128, BC412, Interleaved 2 of 5, UPC/EAN, Codabar, Code 93, Pharmacode, PLANET, Postnet, Japanese Post, Australian Post, Royal Mail, Intelligent Mail, KIX
	2D Symbologies	Data Matrix (ECC 0-200), QR Code, Micro QR Code, Aztec Code, DotCode, DMRE
	Stacked Symbologies	PDF417, MicroPDF417, GS1 Databar (Composite and Stacked)
Reading Performance *2	Number of Reading Digits	No Upper Limit (depending on bar width and reading distance)
	Reading Distance / Field of View	Based on Lens Selection and Code Size
	Pitch Angle (α) *3	$\pm 30^\circ$
	Skew Angle (β) *3	$\pm 30^\circ$
	Tilt Angle (γ) *3	$\pm 180^\circ$
Image	Resolution, Pixel Size	2464 (H) x 2056 (V) – 3.45 μm Pixel Size
	Color / Monochrome	Monochrome CMOS
	Shutter	Global Shutter
	Frames per Second	35 FPS for 5 MP
	Exposure	16 μs to 400 msec
Image Logging		FTP
Trigger		External Trigger (Edge or Level), Communication Trigger (Ethernet, RS-232C)
Trigger to Strobe Latency + Jitter		320 μs + 65 μs
I/O Specifications	Input Signals	Trigger Input, New Master, and Default – Bi-Directional Inputs, Optoisolated, 4.5 – 28 V rated (10 mA @ 28 VDC)
	Output Signals	3 Signals: Bi-Directional, Optoisolated, 1 – 28 V rated, ($I_{CE} < 100$ mA at 24 VDC, current limited by user)
Communication	Connectivity	RS-232C, Ethernet TCP/IP, EtherNet/IP™, PROFINET
	Ethernet Specifications	1000BASE-T
Indicator LEDs		LINK (Amber), PWR (Green)
Power Supply Voltage		Power over Ethernet (IEEE 802.3af) / 24 VDC +/- 20%, External Input via IO *4
Current Consumption		PoE (44-57 VDC): 0.10 A or 24 VDC: 0.15 A
Environmental Immunity *5	Ambient Temperature Range	Operating: 0 to 40° C; Storage: –25 to 65° C (No Icing or Condensation)
	Ambient Humidity Range	Operating and Storage: 25% to 85% (Non-Condensing)
	Ambient Atmosphere	No Corrosive Gases
	Vibration Tolerance	Oscillation Frequency: 10 to 150 Hz; Half Amplitude: 0.35 mm; Vibration Direction: X/Y/Z; Sweep Time: 8 Minutes/Count; Sweep Count: 10 Times
	Shock Resistance (Destructive)	Impact Force: 150 m/s ² , Test Direction: 6 Directions, 3 Times Each (Up / Down, Front / Behind, Left / Right)
	Degree of Protection	IEC 60529 – IP40
Weight	Main Body Only	103.4 g
	Packaging Weight	219.1 g
Dimensions		40 mm (W) x 61 mm (D) x 30 mm (H)
Accessories		ReadMeFirst, CE Compliance Sheet, Protocol Support Table
EMC / Safety		EN 55032:2012/AC:2013, EN 55035:2017, EN 62368-1:2014/AC FCC Part 15, Subpart B (Class B), UL 60950-1 BIS, RCM, KC EAC, and BSMI Pending
Materials		Aluminum Diecast, Alumite (Black)
Software		WebLink 3.0

*1. These symbologies are supported based on Omron's read capability validation standard. Omron recommends that validation be performed for each application.

*2. Unless otherwise specified, reading performance is defined with center of field of view, angle $R = \infty$.

*3. Pitch angle

Skew angle

Tilt angle

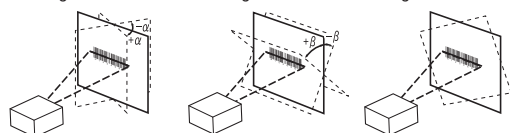

*4. Camera operates External Input at 24 VDC when supplied at the same time as PoE.

*5. In an electrically noisy environment, use only the V440-F in combination with a noise filter cable (V430-W□F-□M) to ensure proper operation.

V440-F

Dimensions

V440-F C-Mount Code Reader

(Unit: mm)

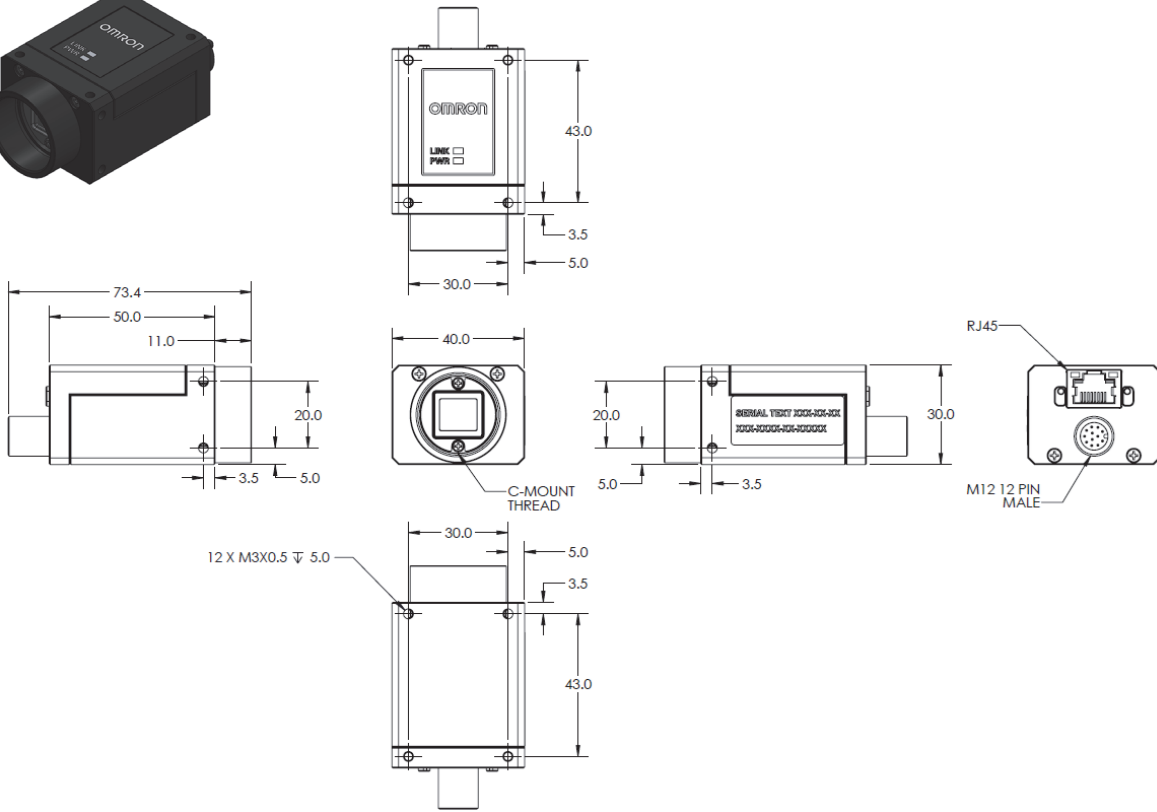

1/4-20 Reader Mounting Block Kit V440-AM0

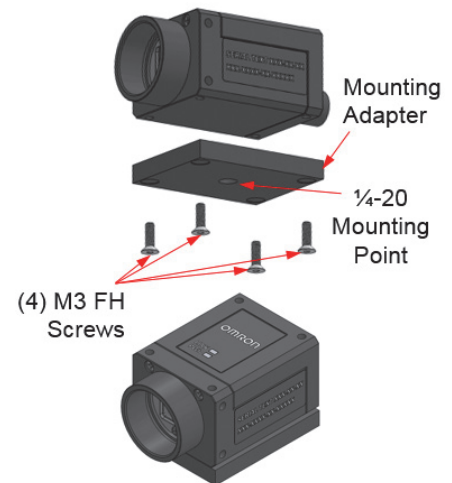
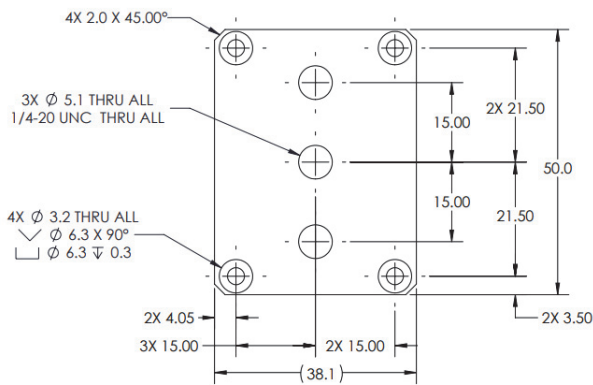
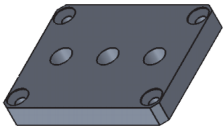

Smart Series R-70 Ring Light to V440-F Mounting Bracket Kit V440-AM1

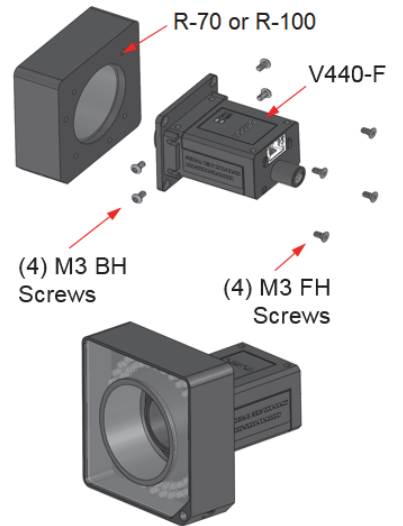
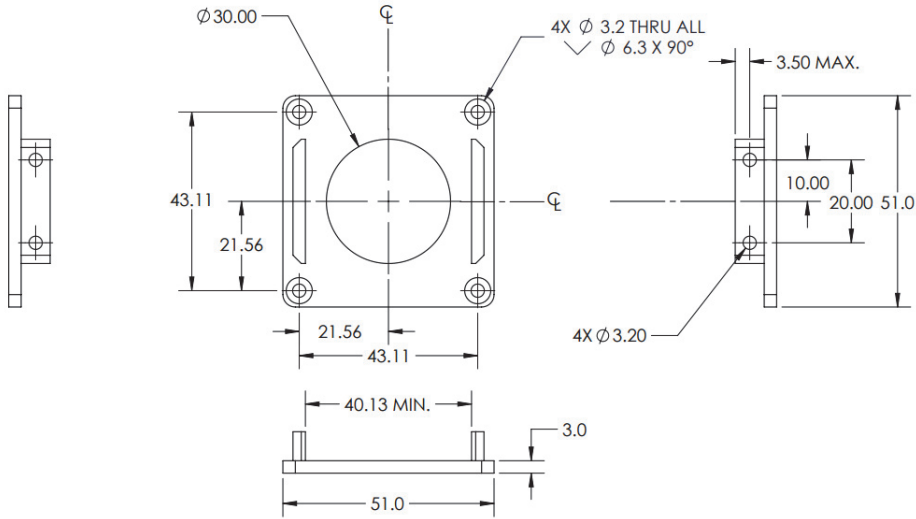
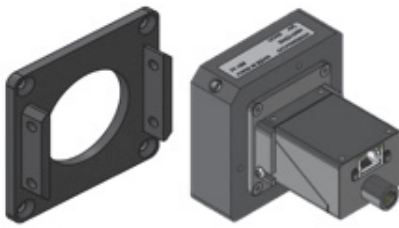

Smart Series R-100 Ring Light to V440-F Mounting Bracket Kit V440-AM2

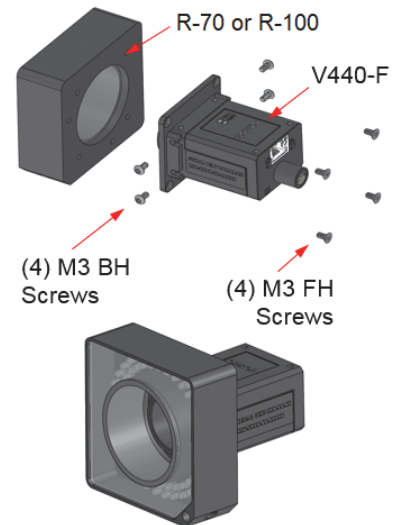
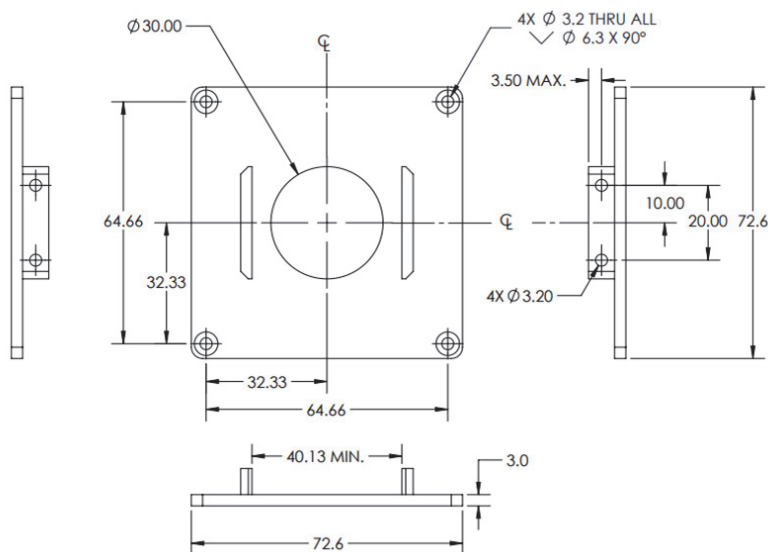
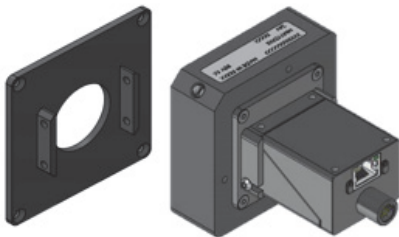

V440-F

Smart Series R-70 Ring Light Polarizer Kit 98-9000301-01

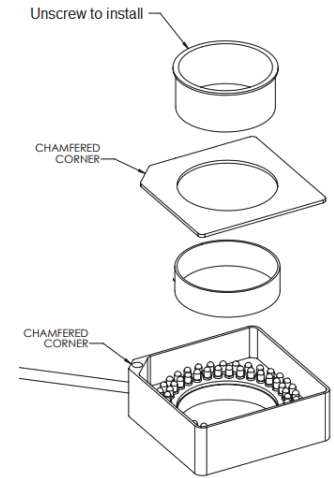
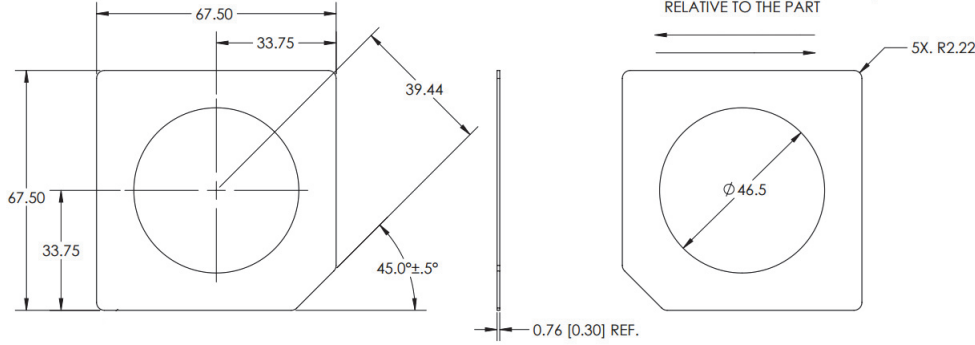
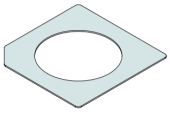

Smart Series R-100 Ring Light Polarizer Kit 98-9000302-01

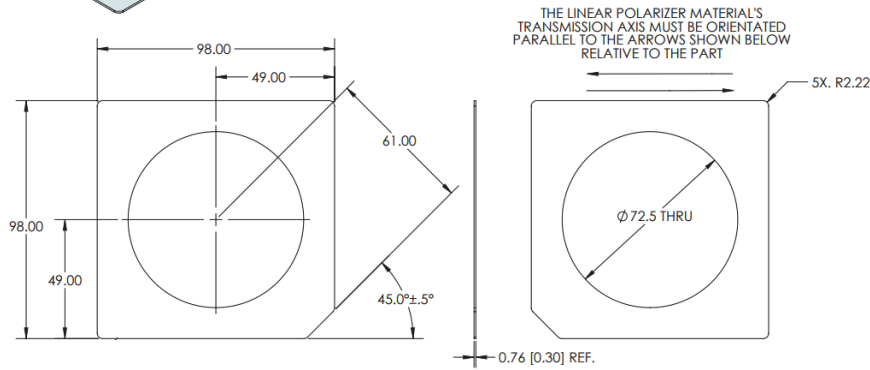
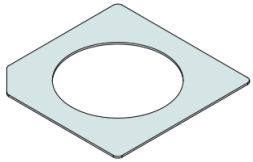

QX-1 Photo Sensor, M12 4-Pin Plug, NPN – 2 Meters – Light ON / Dark ON 99-9000016-01

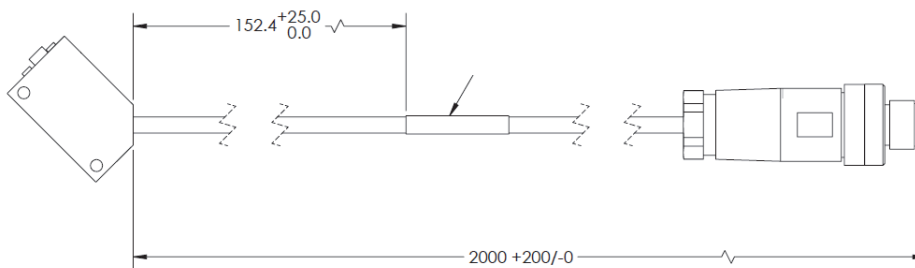

QX-1 Interconnect Module – Power, Trigger, Smart Light Control Breakout
98-000103-02

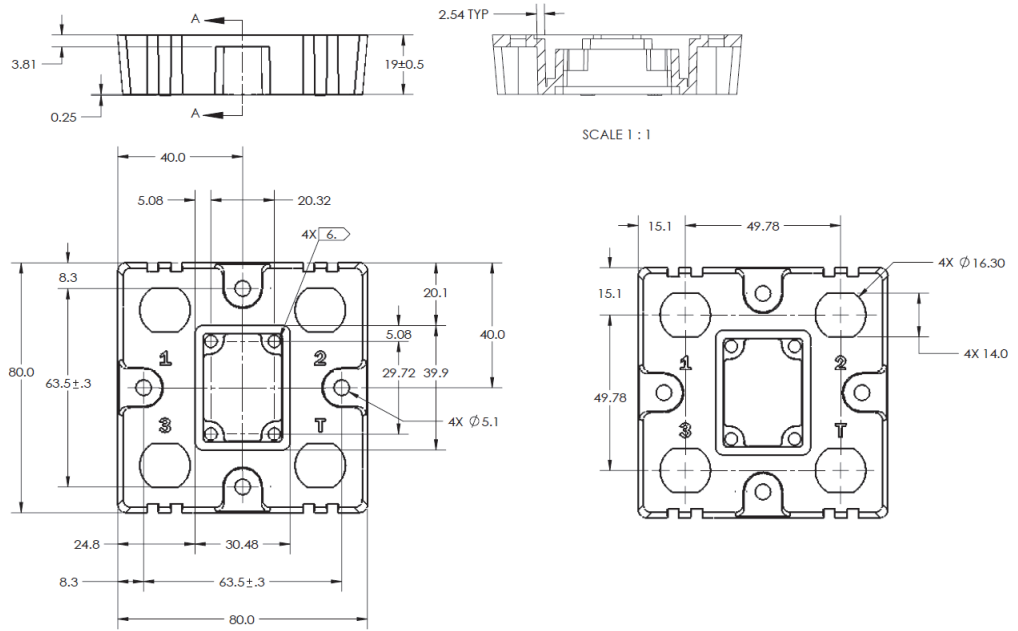

QX-1 Field-Wireable M12 4-Pin Plug for Any Trigger Source or Photo Sensor – Screw Terminals
98-9000239-01

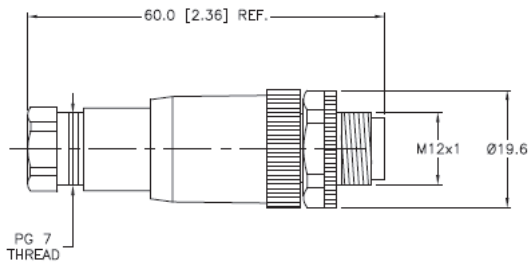

Power Supply, 100-240VAC, +24VDC, M12 12-Pin Socket – 1 Meter – U.S. / Euro Plug
97-000012-01

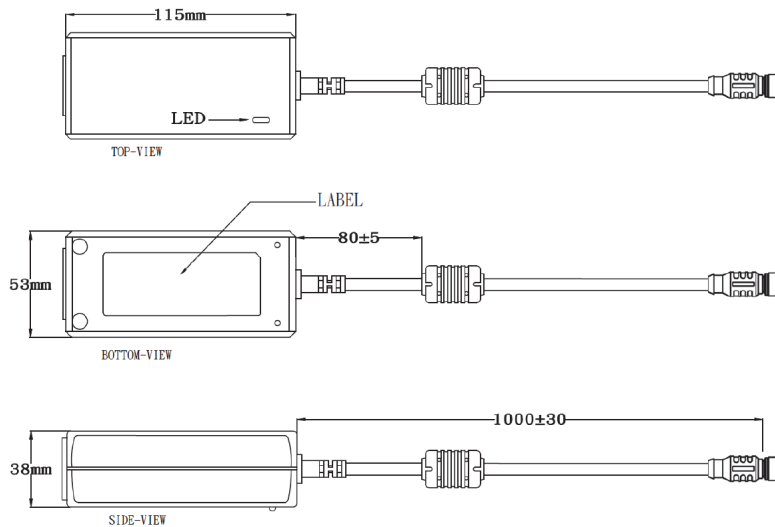

V440-F

Omron Microscan Smart Light Series – Integrated Power and Strobe Control Module
See Omron Microscan Smart Light Offering – Ring, DOAL, Large Area Lighting

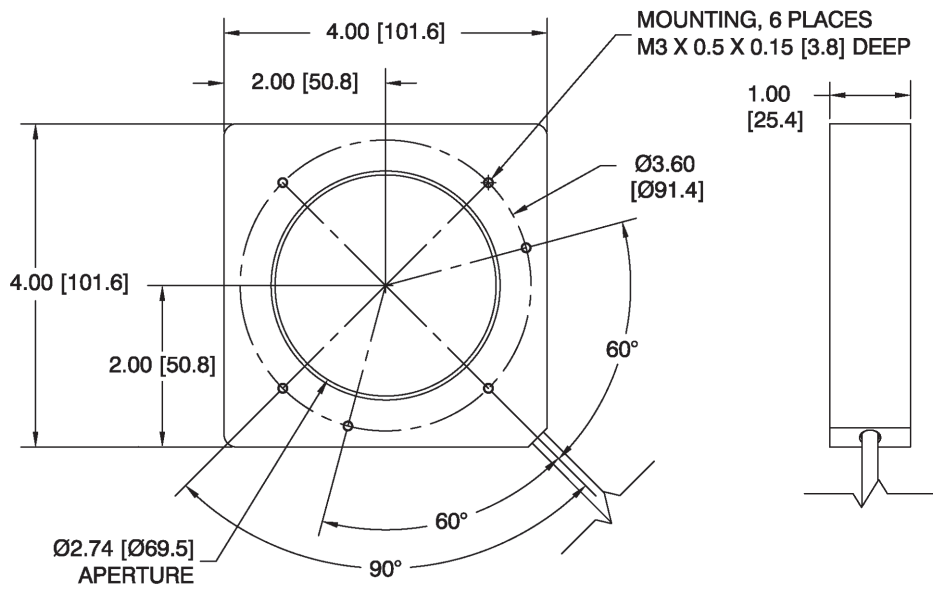
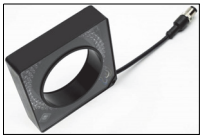

Reader to QX-1 Interconnect Cables – 1 Meter, 3 Meters, or 5 Meters
M12 Socket to M12 Plug
QX-1 is used as breakout module for common IO signals and power.
V430-WQ-1M
V430-WQ-3M
V430-WQ-5M

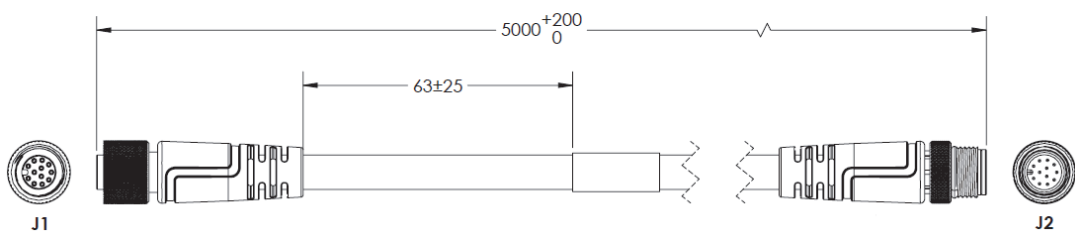
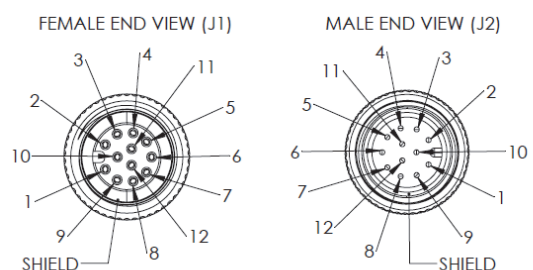
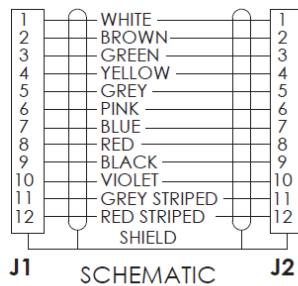
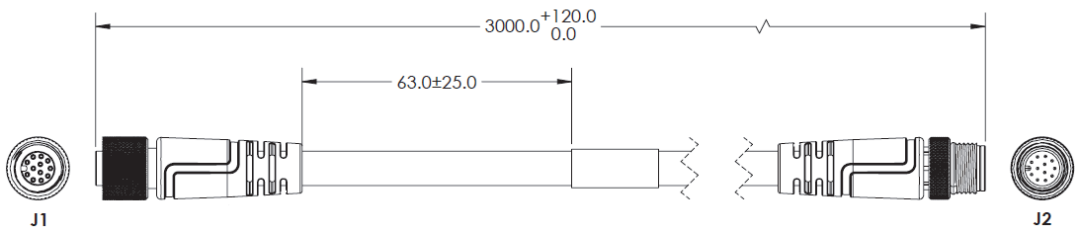
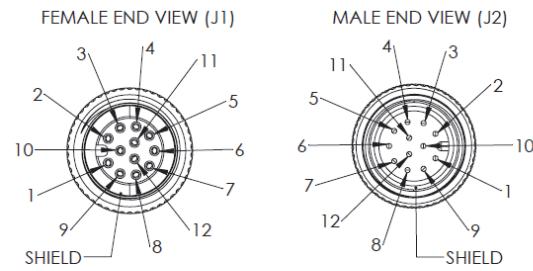
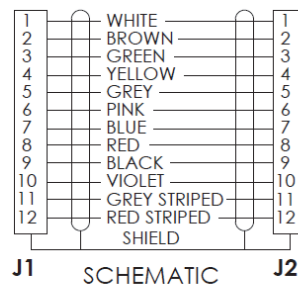
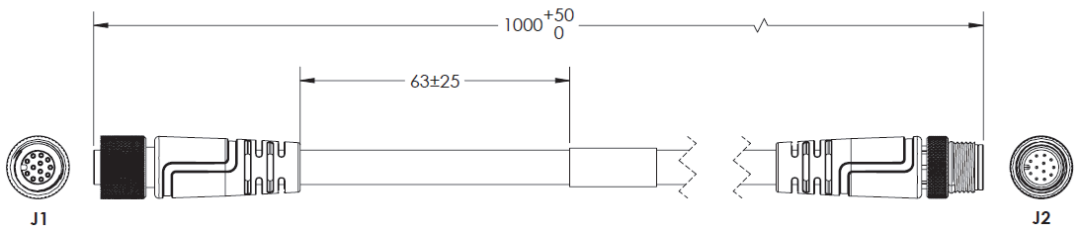
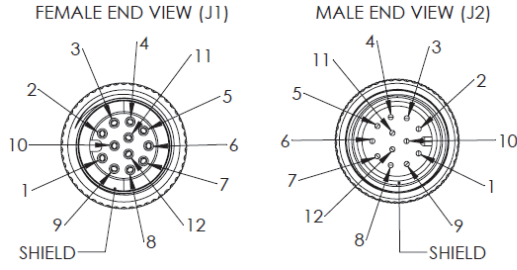
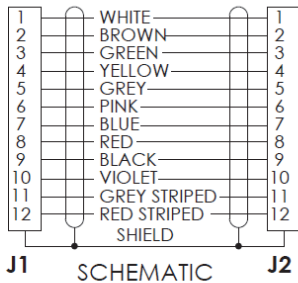

V440-F

M12 Socket to M12 Plug, with Power Filter – 300 mm V430-WQF-1M

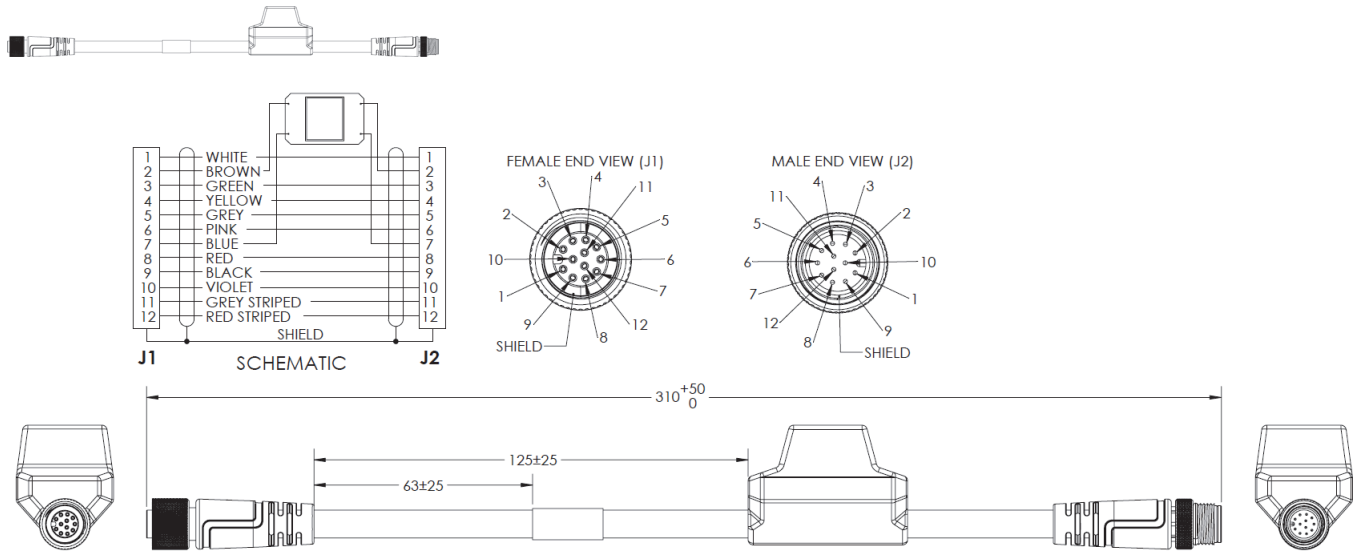

QX-1 M12 to Smart Light Power and Strobe Control Cables – 3 Meters M12 Plug on QX-1 to 5 Pin Socket on Light 61-000204-01 (Continuous Power) 61-000218-01 (Strobe Control)

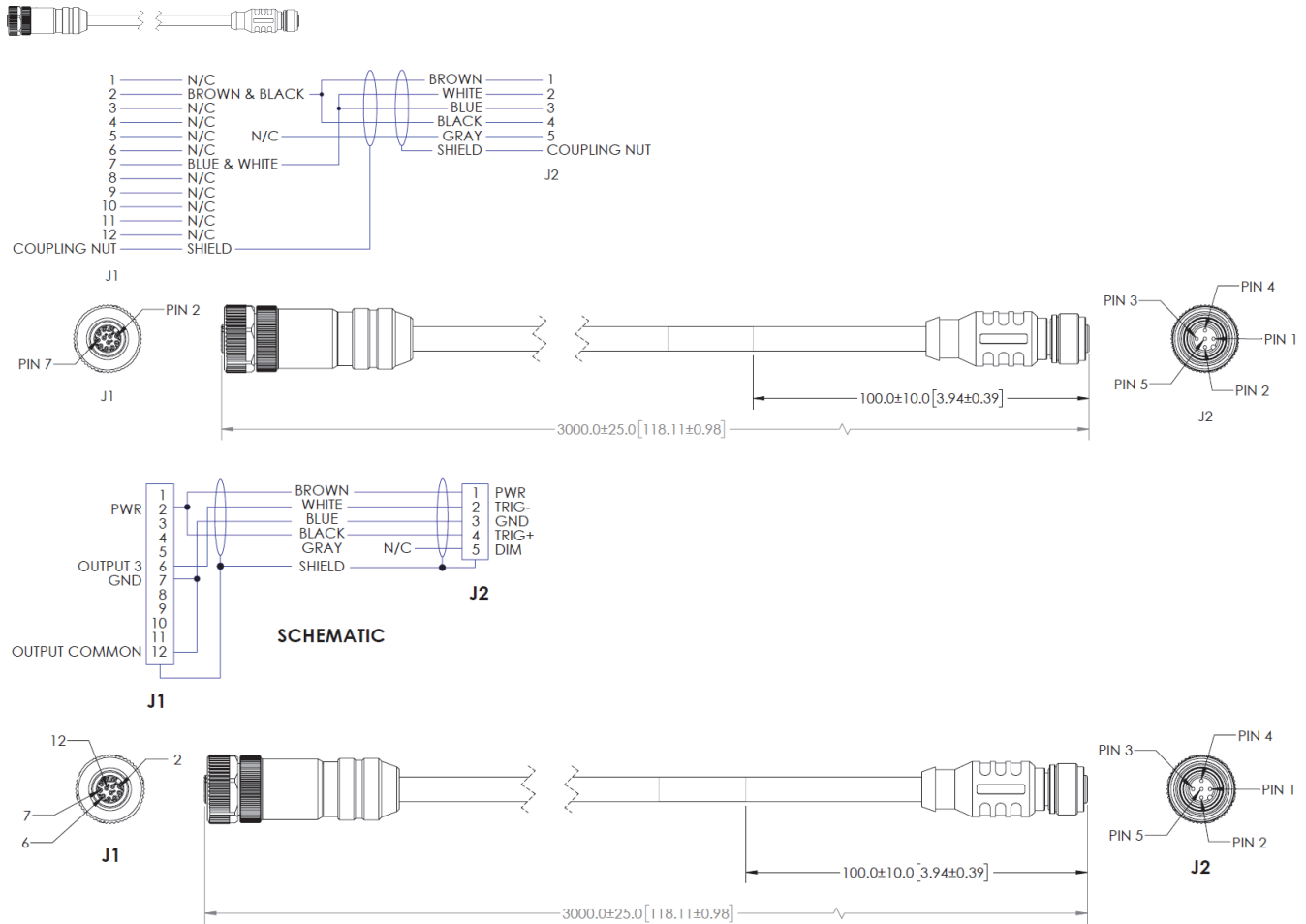

Y Cable, Reader/Power and Smart Light Power (Continuous On) – 1 Meter
61-9000135-01

Y Cable, Reader/Power and Smart Light Strobe Control – 1 Meter
61-9000137-01

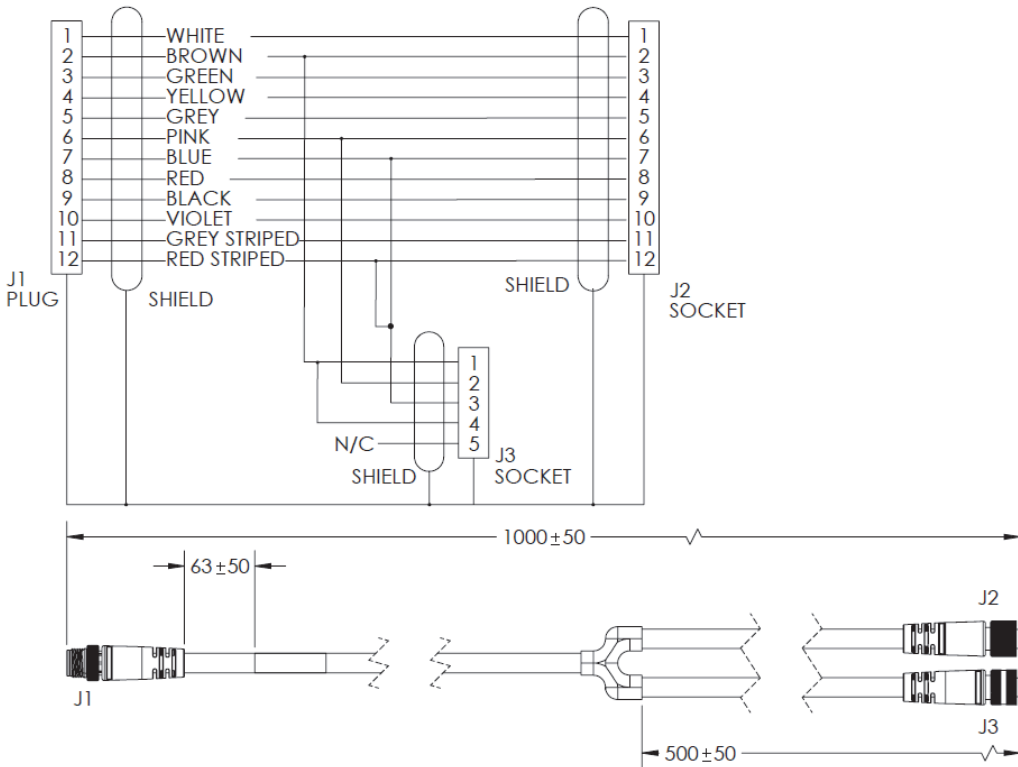
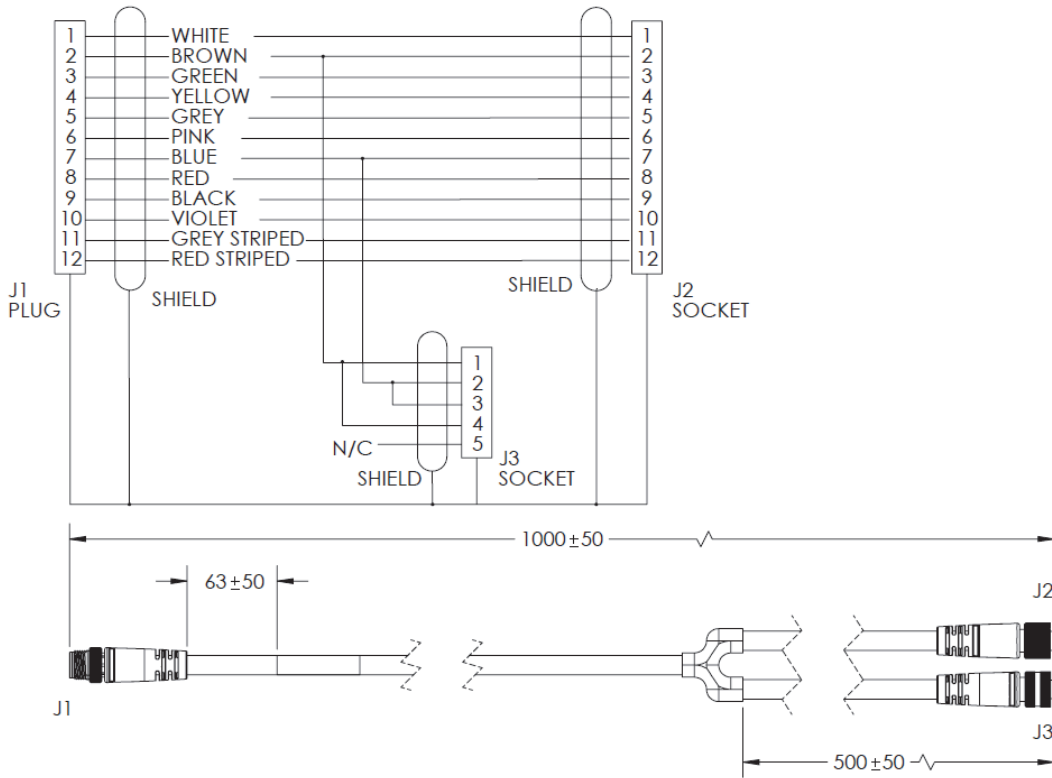
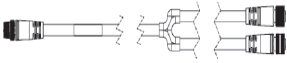

V440-F

M12 to Flying Leads Cable, Straight Power, IO, RS-232, USB – 3 Meters or 5 Meters
 V430-W8-3M
 V430-W8-5M

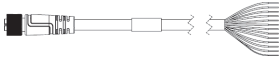

Pin	Function
1	Trigger
2	Power (+VIN)
3	Default
4	New Master
5	Output 1
6	Output 3
7	Ground (-VIN)
8	Input Common
9	RS-232 (Host) RxD
10	RS-232 (Host) TxD
11	Output 2
12	Output Common

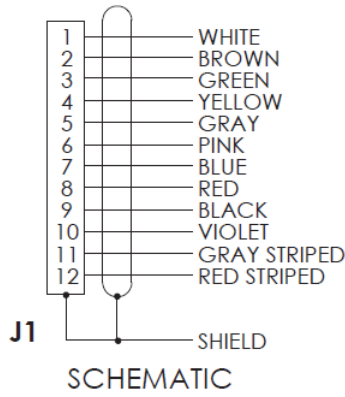

FEMALE END VIEW (J1)

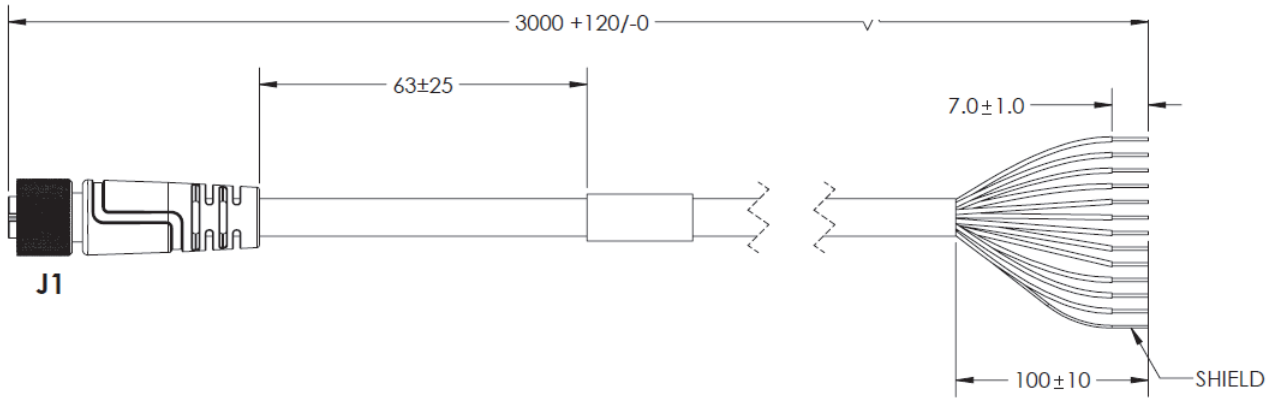
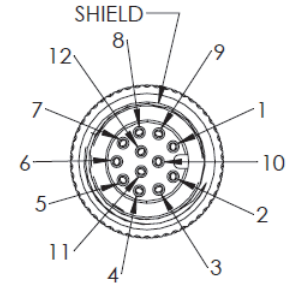

Pin	Function
1	Trigger
2	Power (+VIN)
3	Default
4	New Master
5	Output 1
6	Output 3
7	Ground (-VIN)
8	Input Common
9	RS-232 (Host) RxD
10	RS-232 (Host) TxD
11	Output 2
12	Output Common

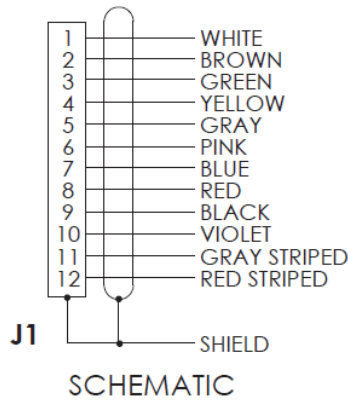

FEMALE END VIEW (J1)

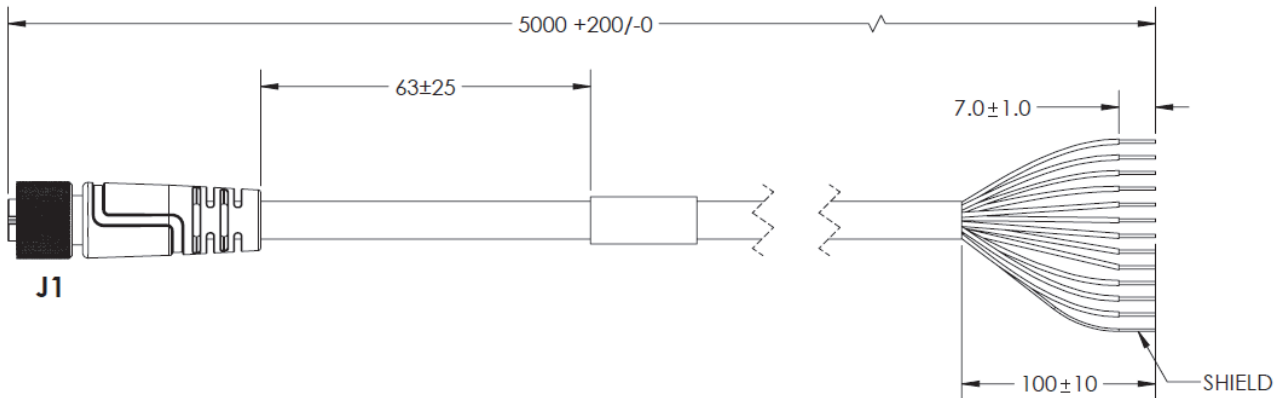
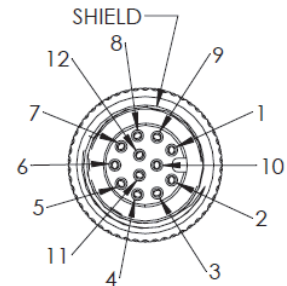

M12 to Flying Leads Cable, with Power Filter – 3 Meters or 5 Meters
V430-W8F-3M
V430-W8F-5M

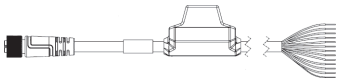

Pin	Function
1	Trigger
2	Power (+VIN)
3	Default
4	New Master
5	Output 1
6	Output 3
7	Ground (-VIN)
8	Input Common
9	RS-232 (Host) RxD
10	RS-232 (Host) TxD
11	Output 2
12	Output Common

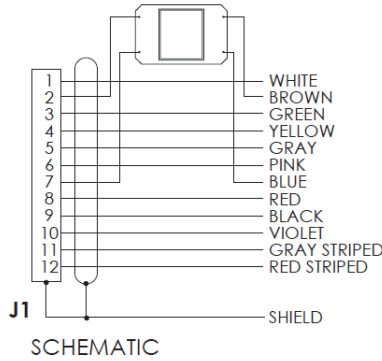

FEMALE END VIEW (J1)

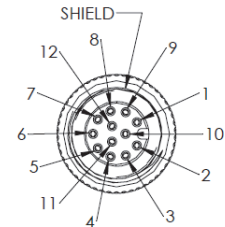

SCHEMATIC

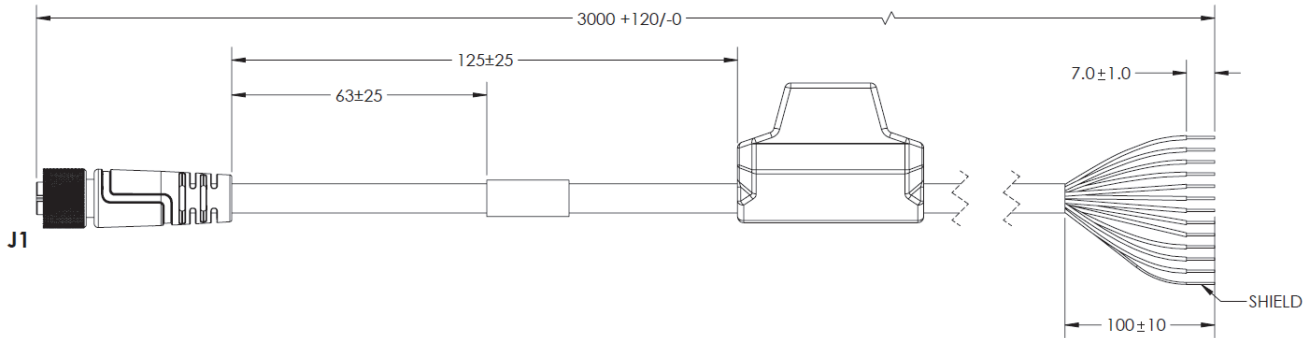

Pin	Function
1	Trigger
2	Power (+VIN)
3	Default
4	New Master
5	Output 1
6	Output 3
7	Ground (-VIN)
8	Input Common
9	RS-232 (Host) RxD
10	RS-232 (Host) TxD
11	Output 2
12	Output Common

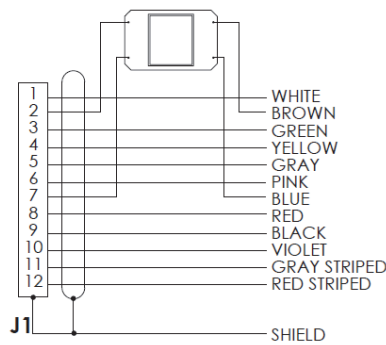

FEMALE END VIEW (J1)

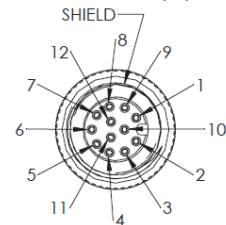

SCHEMATIC

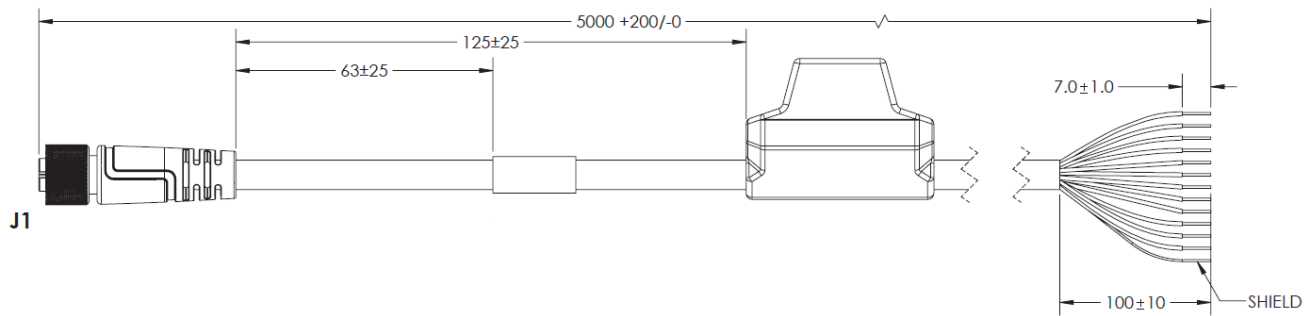

V440-F

M12 to RS-232 Breakout – 1 Meter or 3 Meters V430-WR-1M V430-WR-3M

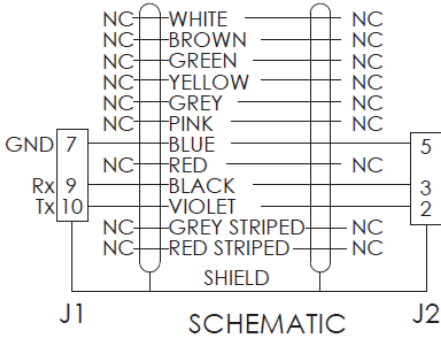

M12 END VIEW (J1)

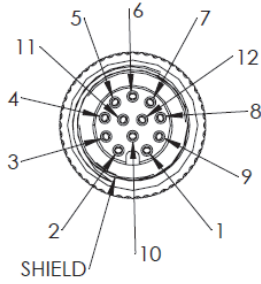

DB9 END VIEW (J2)

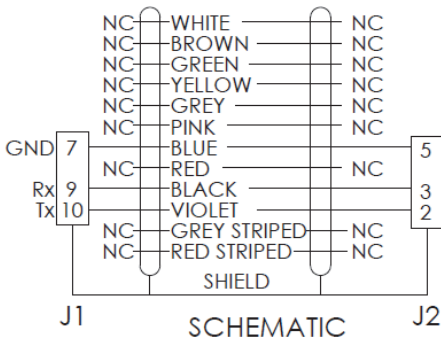
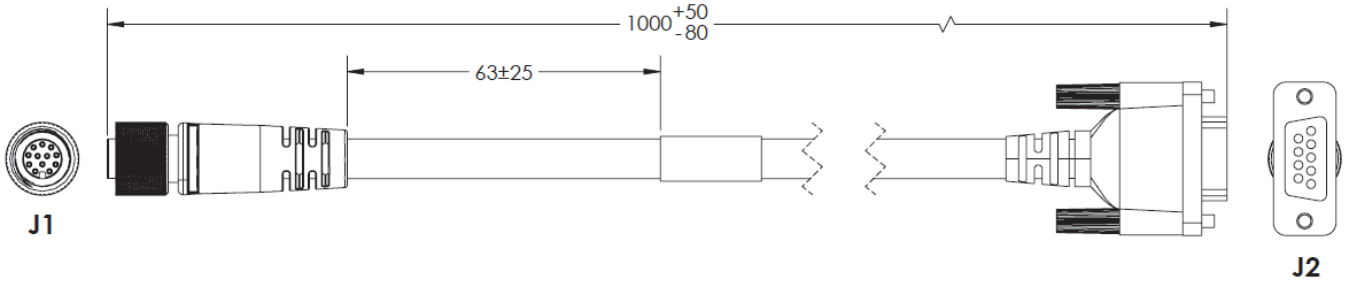
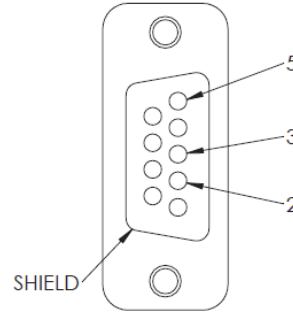

M12 END VIEW (J1)

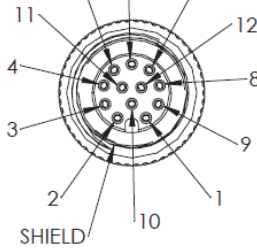

DB9 END VIEW (J2)

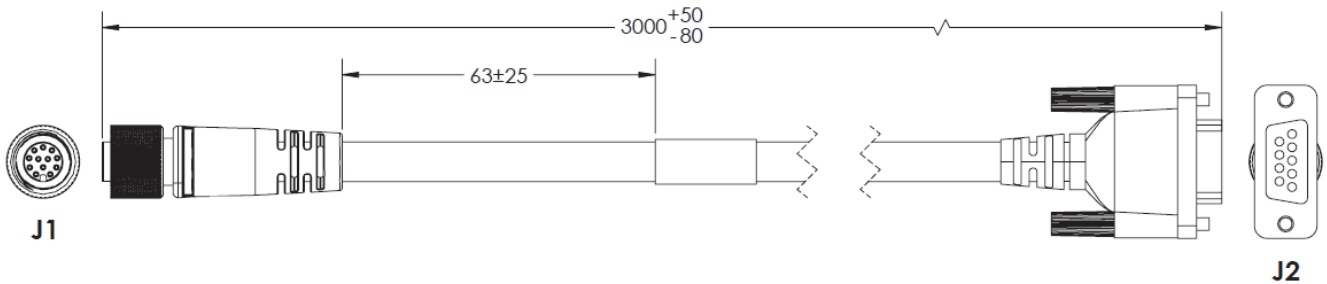
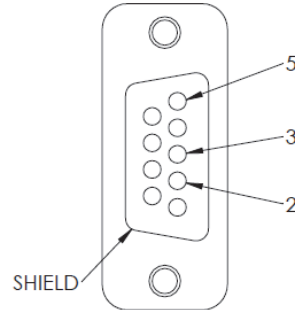

**Reader to QX-1 Interconnect Cables with RS-232 Breakout – 2.7 Meters
V430-WQR-3M**

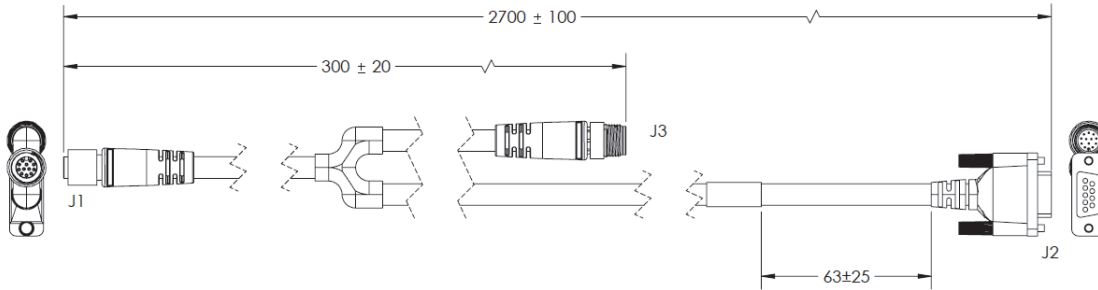
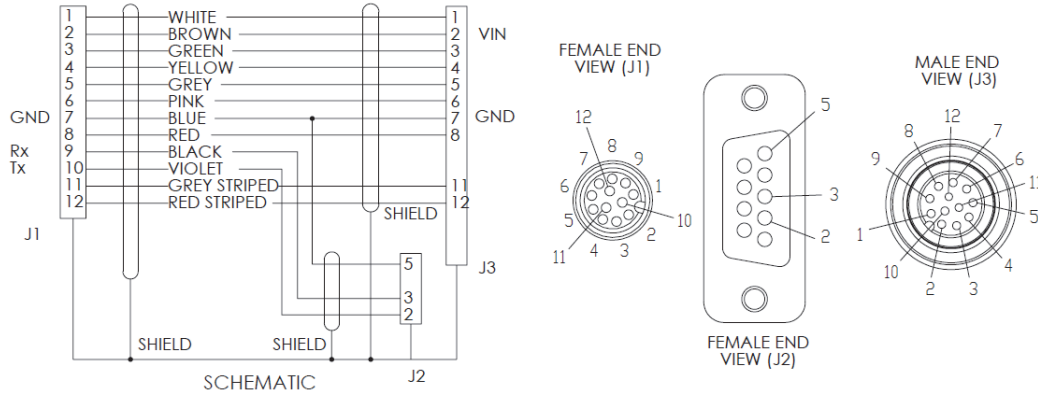
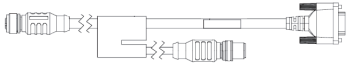

**Reader to QX-1 Interconnect Cables with USB Keyboard Wedge Breakout – 2.7 Meters
V430-WQK-3M**

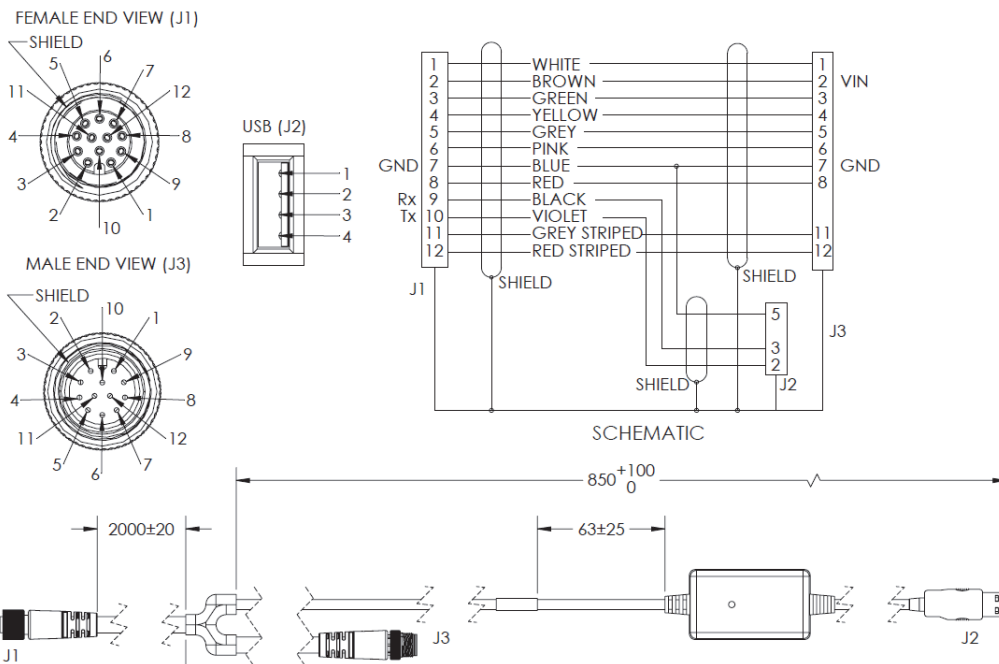
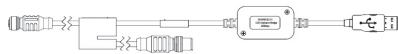

V440-F

Smart Series Light Cable 5 Pin M12 Female to Flying Leads, 3 Meters and 5 Meters

61-000186-01

61-000187-01

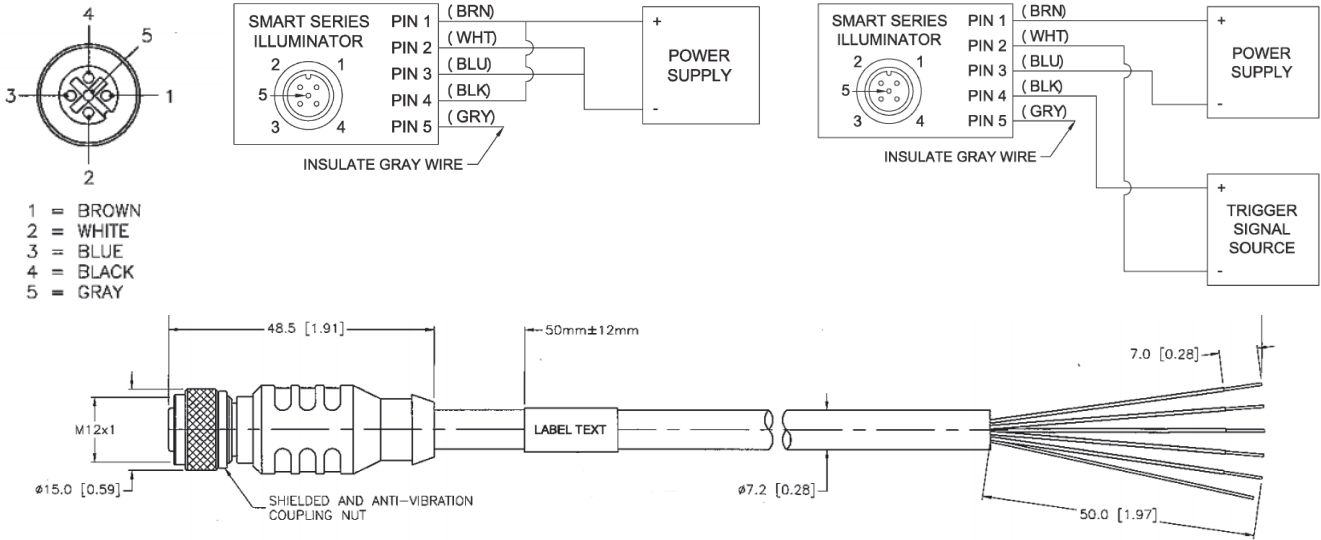

DSP60 24VDC 2.5A DIN Mount Power Supply NER-011504100

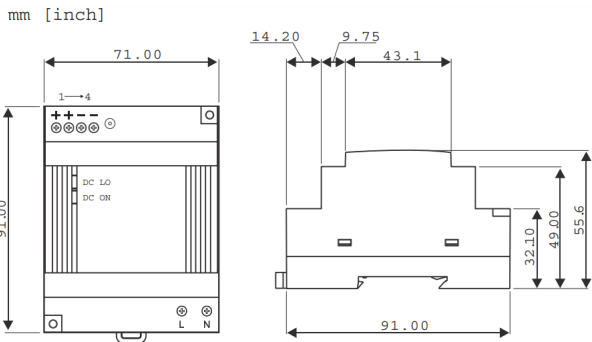

Kit, Spot Light, Blue, Telecentric Lens with Flying Leads Extension Cable 98-9000304-01

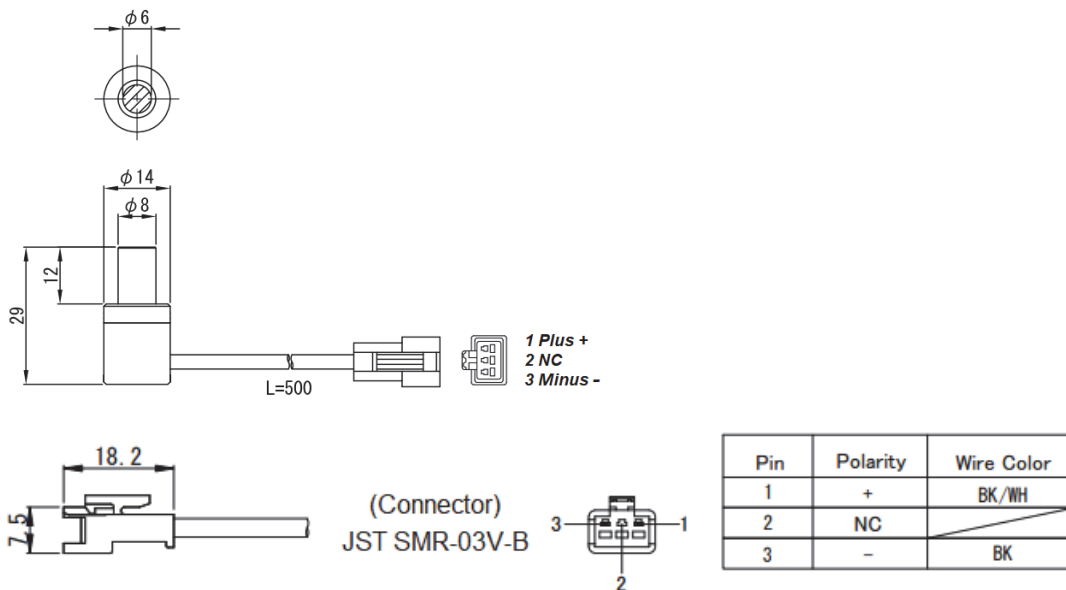

Spot Light Extension Cable, Flying Leads, 5M

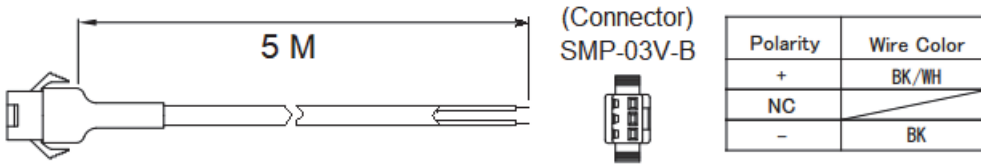

Industrial High-Flex Ethernet Cables with Jack Screws and RJ45, 2 Meters, 5 Meters, and 7 Meters

- 98-000133-01
- 98-000134-01
- 98-000134-02

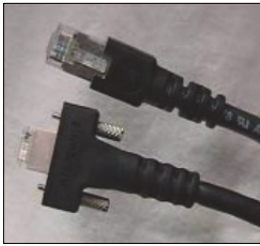

Industrial High-Flex Ethernet Cables

Industrial High-Flex cables provide an interface between V440-F readers and other devices. These cables are designed for harsh environments that could damage a traditional CAT 5 cable. The overmold design provides increased strain relief. Thumbscrew locking keeps the connection secure despite shock and vibration. The double-shielded design provides extra protection in industrial applications.

High-Flex cables are designed to withstand 12 million+ flex cycles. The TPE jacket provides additional protection from elements such as oil, water, and abrasion.

Cable Specifications	
Overall Diameter	.245 Inches
Max. Temperature	80 Degrees C
Jacket Color	Black
UL/CSA Rated	Yes
Min. Bend Radius	2.45 Inches
Flame Rating	FT-1

Primary Components	
Cable	4 Twisted Pairs
Connector A	Standard RJ45
Connector B	Standard RJ45

V440-F

Related Manuals

Model	Part Number	Manual
V440-F	84-9000440-02	V440-F C-Mount Code Reader User Manual
	84-9350045-02	V440-F Communication Manual
	84-9200005-03	WebLink 3.0 Help (Accessible from the Help menu in the WebLink user interface)

Terms and Conditions Agreement

Read and understand this catalog.

Please read and understand this catalog before purchasing the products. Please consult your OMRON representative if you have any questions or comments.

Warranties.

- (a) Exclusive Warranty. Omron's exclusive warranty is that the Products will be free from defects in materials and workmanship for a period of twelve months from the date of sale by Omron (or such other period expressed in writing by Omron). Omron disclaims all other warranties, express or implied.
- (b) Limitations. OMRON MAKES NO WARRANTY OR REPRESENTATION, EXPRESS OR IMPLIED, ABOUT NON-INFRINGEMENT, MERCHANTABILITY OR FITNESS FOR A PARTICULAR PURPOSE OF THE PRODUCTS. BUYER ACKNOWLEDGES THAT IT ALONE HAS DETERMINED THAT THE PRODUCTS WILL SUITABLY MEET THE REQUIREMENTS OF THEIR INTENDED USE.

Omron further disclaims all warranties and responsibility of any type for claims or expenses based on infringement by the Products or otherwise of any intellectual property right. (c) Buyer Remedy. Omron's sole obligation hereunder shall be, at Omron's election, to (i) replace (in the form originally shipped with Buyer responsible for labor charges for removal or replacement thereof) the non-complying Product, (ii) repair the non-complying Product, or (iii) repay or credit Buyer an amount equal to the purchase price of the non-complying Product; provided that in no event shall Omron be responsible for warranty, repair, indemnity or any other claims or expenses regarding the Products unless Omron's analysis confirms that the Products were properly handled, stored, installed and maintained and not subject to contamination, abuse, misuse or inappropriate modification. Return of any Products by Buyer must be approved in writing by Omron before shipment. Omron Companies shall not be liable for the suitability or unsuitability or the results from the use of Products in combination with any electrical or electronic components, circuits, system assemblies or any other materials or substances or environments. Any advice, recommendations or information given orally or in writing, are not to be construed as an amendment or addition to the above warranty.

See <http://www.omron.com/global/> or contact your Omron representative for published information.

Limitation on Liability; Etc.

OMRON COMPANIES SHALL NOT BE LIABLE FOR SPECIAL, INDIRECT, INCIDENTAL, OR CONSEQUENTIAL DAMAGES, LOSS OF PROFITS OR PRODUCTION OR COMMERCIAL LOSS IN ANY WAY CONNECTED WITH THE PRODUCTS, WHETHER SUCH CLAIM IS BASED IN CONTRACT, WARRANTY, NEGLIGENCE OR STRICT LIABILITY.

Further, in no event shall liability of Omron Companies exceed the individual price of the Product on which liability is asserted.

Suitability of Use.

Omron Companies shall not be responsible for conformity with any standards, codes or regulations which apply to the combination of the Product in the Buyer's application or use of the Product. At Buyer's request, Omron will provide applicable third party certification documents identifying ratings and limitations of use which apply to the Product. This information by itself is not sufficient for a complete determination of the suitability of the Product in combination with the end product, machine, system, or other application or use. Buyer shall be solely responsible for determining appropriateness of the particular Product with respect to Buyer's application, product or system. Buyer shall take application responsibility in all cases.

NEVER USE THE PRODUCT FOR AN APPLICATION INVOLVING SERIOUS RISK TO LIFE OR PROPERTY OR IN LARGE QUANTITIES WITHOUT ENSURING THAT THE SYSTEM AS A WHOLE HAS BEEN DESIGNED TO ADDRESS THE RISKS, AND THAT THE OMRON PRODUCT(S) IS PROPERLY RATED AND INSTALLED FOR THE INTENDED USE WITHIN THE OVERALL EQUIPMENT OR SYSTEM.

Programmable Products.

Omron Companies shall not be responsible for the user's programming of a programmable Product, or any consequence thereof.

Performance Data.

Data presented in Omron Company websites, catalogs and other materials is provided as a guide for the user in determining suitability and does not constitute a warranty. It may represent the result of Omron's test conditions, and the user must correlate it to actual application requirements. Actual performance is subject to the Omron's Warranty and Limitations of Liability.

Change in Specifications.

Product specifications and accessories may be changed at any time based on improvements and other reasons. It is our practice to change part numbers when published ratings or features are changed, or when significant construction changes are made. However, some specifications of the Product may be changed without any notice. When in doubt, special part numbers may be assigned to fix or establish key specifications for your application. Please consult with your Omron's representative at any time to confirm actual specifications of purchased Product.

Errors and Omissions.

Information presented by Omron Companies has been checked and is believed to be accurate; however, no responsibility is assumed for clerical, typographical or proofreading errors or omissions.

- EtherNet/IP™ is a trademark of ODVA.
- QR code is the registered trademark of DENSO WAVE.
- Other company names and product names in this document are the trademarks or registered trademarks of their respective companies.
- The product photographs and figures that are used in this catalog may vary somewhat from the actual products.

Note: Do not use this document to operate the unit.

OMRON Corporation Industrial Automation Company

Kyoto, JAPAN

Contact: www.ia.omron.com

Regional Headquarters

OMRON EUROPE B.V.
Wegalaan 67-69, 2132 JD Hoofddorp
The Netherlands
Tel: (31)2356-81-300/Fax: (31)2356-81-388

OMRON ELECTRONICS LLC
2895 Greenspoint Parkway, Suite 200
Hoffman Estates, IL 60169 U.S.A.
Tel: (1) 847-843-7900/Fax: (1) 847-843-7787

OMRON ASIA PACIFIC PTE. LTD.
No. 438A Alexandra Road # 05-05/08 (Lobby 2),
Alexandra Technopark,
Singapore 119967
Tel: (65) 6835-3011/Fax: (65) 6835-2711

OMRON (CHINA) CO., LTD.
Room 2211, Bank of China Tower,
200 Yin Cheng Zhong Road,
PuDong New Area, Shanghai, 200120, China
Tel: (86) 21-5037-2222/Fax: (86) 21-5037-2200

Authorized Distributor:

© OMRON Corporation 2021 All Rights Reserved.
In the interest of product improvement,
specifications are subject to change without notice.

Cat. No. Q342-E-01 (SP124A-EN-0421)

0621 (0621)